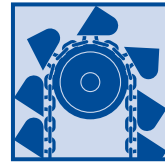


# Components for Bucket Elevators



**HEKO Ketten GmbH**








# Contents



	page
<b>1.0 Overview</b>	3
<b>2.0 HEKO round link chains</b>	4
2.1 Heat treatment	4
2.2 Technical data for round link chains	5
2.3 Dimensions and technical data for round link chains	6
<b>3.0 HEKO bucket attachments</b>	7
3.1 Technical data for bucket elevator attachments	7
3.2 Chain shackles type TS/TS-N/TS-L	8
3.3 Endless chain system TS, TS-N and TS-L	9
3.4 Chain shackles to type DIN 5699 and type DIN 745	10
3.5 Chain shackle type S	11
3.6 Special chain shackles type R	11
3.7 Nuts and safety elements	11
3.8 Plug-in bucket attachment type ST	12
<b>4.0 HEKO chain locks</b>	13
4.1 Chain locks type B and type D	13
4.2 Chain lock type E	13
<b>5.0 HEKO bucket elevator systems and their components</b>	14
5.1 Scheme of chain bucket elevators	14
5.2 Technical data for elevator buckets	16
<b>6.0 HEKO chain wheels</b>	17
6.1 Toothless chain wheels with „HEKOFLEX“ – plastic rims type RUH and type RUHS	17
6.2 Toothless chain wheels with replaceable steel rim segments type RUA	18
6.3 Toothless chain wheels with replaceable steel rim segments type RUU	19
6.4 Toothless chain wheel with replaceable hard cast iron segments type SUR, type KS and type KSE	20
6.5 Toothless chain wheels, one piece, in grey cast iron, type GGB	21
6.6 Toothless chain wheels with replaceable steel rim segments type RUR	21
6.7 Toothless chain wheels with replaceable steel rim segments type RUP	22
6.8 Toothless chain wheels, in steel with split hub, type RUG	23
6.9 Bucket guide disc for toothless chain wheel, type RUB	23
6.10 Chain wheels with pocket teeth, in steel, with replaceable rim segments type GTA	24
6.11 Chain wheels with projecting teeth (inside toothed), in steel, with replaceable rim segments, type GIA	25
6.12 Chain wheels with projecting teeth (inside toothed), in steel, with replaceable rim segments, type GIA-3	26
6.13 Chain wheels with projecting teeth (inside toothed), in steel, with Individually replaceable teeth type RIS and return wheels type BS	27
6.14 HEKO chain wheel overview	28
<b>7.0 HEKO elements for bucket elevators</b>	30
7.1 Maintenance-free bearings for bucket elevators and other conveyors	30
7.2 Drive and return wheel shafts	30
7.3 Return and tensioning unit for bucket elevators	31
<b>8.0 HEKO example of bucket elevator sizing</b>	32
<b>9.0 General technical information</b>	33
<b>10.0 Questionnaire – Technical data for bucket elevators</b>	35

# 1.0 Overview

Bucket elevator options			
Description	Type		Chapter
Chain Shackles	Type TS		3.2
Chain Shackles	Type TS-N/TS-L		3.2
Chain Shackles	Type DIN 5699		3.4
Chain Shackles	Type DIN 745		3.4
Chain Shackles	Type S		3.5
Plug-In Bucket	Type ST		3.8

**Figure 1:**  
Bucket elevator options

HEKO chains and accessories for bucket elevators are utilised world-wide to provide solutions to a wide range of transport problems. Apart from chains HEKO's manufacturing scope includes several types of bucket attachments, chain locks, buckets, drive and idling wheels, shafts, and complete, dust-free tensioning/return station assemblies. All HEKO components are matched to ensure compatibility for trouble free operation. Continued development in close co-operation with our customers ensures solutions,

which meet today's ever-increasing demand for improved safety and cost effectiveness. Companies in the cement, sugar, chemical, gypsum, glass, quarry, food industries and power plants are counted among our major clients. World-wide support is provided by HEKO for sizing and optimising equipment. Manufacture of the wear resistant products is carried out at HEKO's manufacturing facilities in Wickede. The certified HEKO Ketten GmbH Management system covers the Quality Management System as per

ISO 9001:2008, the Environmental Management System as per ISO 14001:2009 and the Occupational Health and Safety Assessment Series as per BS OHSAS 18001:2007. Furthermore HEKO is AEOF certified.



## 2.0 HEKO round link chains

**HEKO chains distinguish themselves through:**

- **high quality heat treatment tailored to particular applications**
- **high fatigue strength**
- **close length tolerance of chain pairs**

Modern welding machines are employed for the manufacture of HEKO chains.

Chains are manufactured from a wide range of materials including manganese steels, chrome-nickel steels and fine grain chrome-nickel-molybdenum alloy steels.

Our own, modern, computer-controlled heat treatment processes produce tempered or case hardened chains.

## 2.1 Heat treatment



**Figure 2:**  
Part view of the HEKO hardening shop



**Figure 3:**  
Cross section through the length of a chain link

**HEKO case hardening means:**

- **High breaking load resulting from a tough, fine grain core**
- **High wear resistance resulting from a surface hardness in excess of 800 HV**

Case hardening results in a hard, wear resistant chain shell. HEKO offers 6 hardening depths as standard. In addition HEKO offers various hardening depths to suit individual requirements. A surface hardness of at least 800 HV is supplied as standard.

**HEKO tempered means:**

- **very high breaking loads**

For applications where a high breaking load is taking precedence over hardness, tempered round link chains manufactured from manganese steel, or CrNi or CrNiMo alloy steel are recommended.



**Figure 4:**  
Cross section through the diameter of a chain link

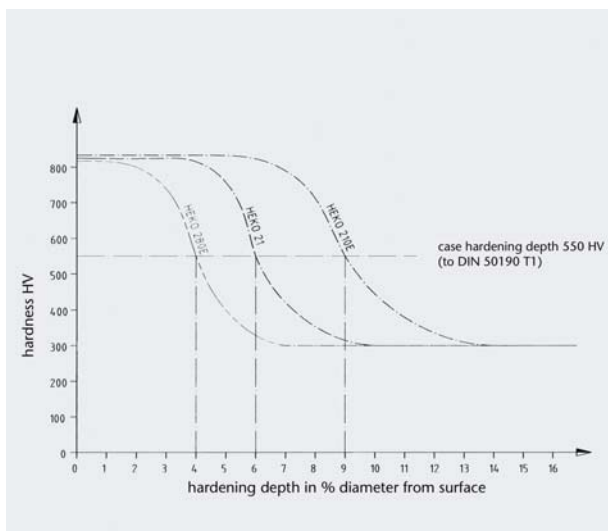
## 2.2 Technical data for round link chains

**Table 1: Technical data for HEKO qualities**

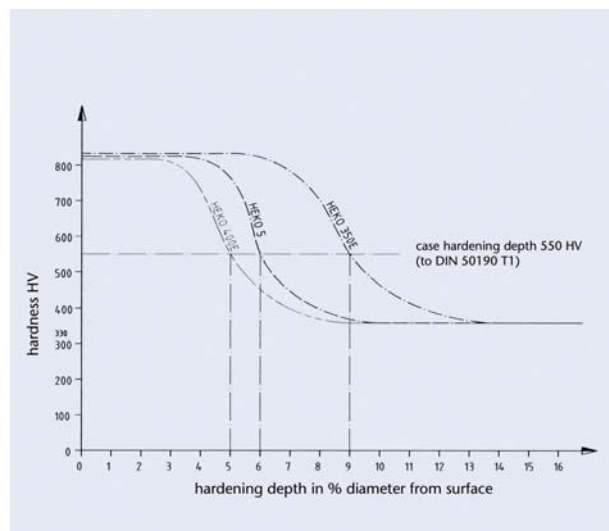
	case hardened qualities manganese steel			case hardened qualities CrNi/ CrNiMo steel		
	HEKO 280E	HEKO 21	HEKO 210E	HEKO 400E	HEKO 5	HEKO 350E
proof stress N/mm <sup>2</sup>	140	125	105	240	150	210
breaking stress N/mm <sup>2</sup>	280 <sub>1)</sub>	250	210 <sub>1)</sub>	400 <sub>1)</sub>	370 <sub>6)</sub>	350 <sub>1)</sub>
contact surface hardness min. joint HV 30	800	800	800	800	800	800
case hardening depth ...d +/-0,01 d after etching	0,07	0,10	0,14 <sub>2)</sub>	0,09	0,10	0,14 <sub>2)</sub>
case hardening depth ...d min. Eht 550	0,04	0,06 <sub>3)</sub>	0,09 <sub>4)</sub>	0,05	0,06 <sub>3)</sub>	0,09 <sub>4)</sub>
<b>product characteristic</b>						
low abrasion	●			●		
medium abrasion		●		●	●	
strong abrasiveness			●			●
<b>dynamic load</b>						
light			●			●
medium		●			●	
heavy	●			●	●	

1) tolerance 10%  
3)  $\geq 30$  mm  $\varnothing = 0,05$  d  
5) Eht = case hardening depth

2) 30 mm  $\varnothing = 0,12$  d, 36-42 mm  $\varnothing = 0,11$  d  
4) 30 mm  $\varnothing = 0,08$  d, 36-42 mm  $\varnothing = 0,07$  d  
6)  $\geq 30$  mm  $\varnothing =$  tolerance 20%



**Figure 5 :**  
Hardness curves for HEKO chains of  
special manganese chain steel



**Figure 6:**  
Hardness curves for HEKO chains of  
chromium-nickel and chromium-nickel-  
molybdenum alloy steels



## 2.3 Dimensions and technical data for round link chains

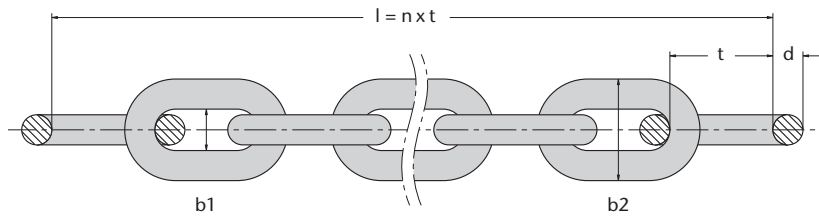


Figure 7: Dimensions for round link chains

Table 2: Dimensions and qualities

Dimensions / mm		DIN chain	weight kg/m	b1 inside width min. (mm)	b2 outside width max. (mm)	case hardened HEKO qualities					
nominal dia. x pitch d x t (mm)	280 E MBK kN					21 MBK kN	210 E MBK kN	400 E MBK kN	5 MBK kN	350 E MBK kN	
10 x 28,0	766	2,3	12,0	36,0	44	39	33	63	58	55	
10 x 35,0	764	2,0	14,0	36,0	44	39	33	63	58	55	
13 x 45,0	764	3,5	18,0	47,0	74	66	56	106	98	93	
14 x 50,0	WN	4,1	16,3	47,0	86	77	65	123	114	108	
16 x 45,0	766	5,8	19,2	58,0	112	100	84	160	148	140	
16 x 56,0	764	5,2	22,0	58,0	112	100	84	160	148	140	
16 x 64,0	WN	5,1	20,0	55,0	112	100	84	160	148	140	
18 x 50,0	766	7,4	21,6	65,0	142	127	107	204	188	178	
18 x 63,0	764	6,5	24,0	65,0	142	127	107	204	188	178	
19 x 75,0	WN	7,6	22,0	63,0	158	141	119	227	210	198	
20 x 56,0	766	9,0	24,0	72,0	175	157	132	251	232	220	
20 x 70,0	764	8,2	27,0	72,0	175	157	132	251	232	220	
22 x 86,0	WN	9,8	26,0	74,0	212	190	160	304	281	266	
23 x 64,0	766	12,0	27,6	83,0	232	207	174	332	307	290	
23 x 80,0	764	11,0	31,0	83,0	232	207	174	332	307	290	
26 x 73,0	766	15,0	31,2	94,0	298	265	223	425	392	371	
26 x 91,0	764	14,0	35,0	94,0	298	265	223	425	392	371	
26 x 100,0	WN	13,5	31,0	87,0	298	265	223	425	392	371	
28 x 78,0	766	18,0	33,6	101,0	344	308	258	492	455	431	
28 x 98,0	764	16,5	36,0	101,0	344	308	258	492	455	431	
30 x 84,0	766	20,0	36,0	108,0	395	353	296	565	523	494	
30 x 105,0	764	19,0	39,0	108,0	395	353	296	565	523	494	
30 x 120,0	WN	17,8	36,0	102,0	395	353	296	565	523	494	
33 x 92,0	766	25,0	43,0	119,0	478	427	359	684	633	598	
33 x 115,0	764	22,5	43,0	119,0	478	427	359	684	633	598	
34 x 136,0	WN	23,8	39,0	113,0	508	453	381	726	672	635	
36 x 101,0	766	29,0	43,2	130,0	570	508	428	814	753	712	
36 x 126,0	764	26,5	47,0	130,0	570	508	428	814	753	712	
38 x 144,0	WN	30,0	44,0	127,0	635	567	476	907	839	794	
39 x 109,0	766	34,0	51,0	140,0	669	597	502	956	884	836	
39 x 136,0	764	31,0	51,0	140,0	669	597	502	956	884	836	
42 x 118,0	766	40,0	50,0	151,0	776	692	582	1108	1025	970	
42 x 147,0	764	36,0	55,0	151,0	776	692	582	1108	1025	970	

MBK = min. breaking load, WN = works standard, d = diameter, t = pitch, other dimensions and qualities on request, including stainless steel and other alloys. Matching of chains and wheels is essential for trouble free operation.

# 3.0 HEKO bucket attachments

## HEKO attachments

- the right solution for every application
- several options to suit individual requirements
- finish self-colour, galvanised or other surface finishes

HEKO offers a wide spectrum of cost effective and safe attachments for elevators. HEKO's attachments are suitable for double-strand elevators. The heat treatment of the attachments will be effected individually to the requirements. There is a choice between different hardened qualities.

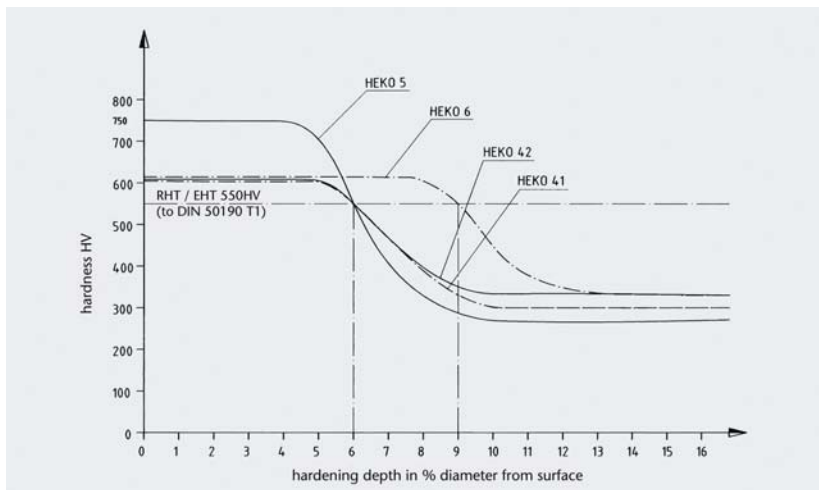
Generally the conveying chains can be supplied as single components or pre-mounted endless chain strands. We will be pleased to assist you in selecting the optimum attachment for your application.

# 3.1 Technical data for bucket elevator attachments

**Table 3: Technical data for HEKO qualities**

	Hardened contact area qualities		CrMo-steel	Case hardened qualities
	Heat treatable steel	CrMo-steel	CrMo-steel	CrNi-steel
	HEKO 4/1	HEKO 4/2	HEKO 6	HEKO 5
proof stress N/mm <sup>2</sup>	125	240	240	150
breaking stress N/mm <sup>2</sup>	280	400	400	370 <sub>4)</sub>
contact surface hardness min. joint HV 1	600	600	600	750
hardening depth d min. after etching	0,1 <sub>1)</sub>	0,1 <sub>1)</sub>	0,14 <sub>1)</sub>	0,1 <sub>1)</sub>
hardening depth d min. Eht <sub>2)</sub> Rht <sub>3)</sub> 550 HV 1	0,06	0,06	0,09	0,06

1) tolerance ...d 0,01 d      2) Eht = case hardened depth  
 3) Rht = effective hardening depth      4) tolerance - 10% ≥ t=105 = -20%



**Figure 8 :**  
Hardness curves for bucket attachments



**Figure 9:**  
Automatic hardness tester (Protocolling of hardness values and hardness curve)

## 3.2 Chain shackles type TS/TS-N/TS-L

Chain shackles type TS / TS-N / TS-L are suitable as bucket attachments for all duties. The shackles are tempered and induction hardened in the contact areas to a hardening depth of at least  $0.14 \times d$ .

Shackles type TS and TS-N can be used with pocket teeth and projecting teeth and toothless chain wheels. Assembly and dismounting of the shackle is possible at any time when using spring pins for the fastening of the closing plates split pins are available optionally.

### Advantages of the TS-Shackles compared to DIN-Shackles

- Locked distance plate, therefore uninterrupted force transmission
- Higher breaking load
- Larger contact surface
- Lower wear
- Easier assembly/dis-assembly
- Interchangeable with shackle to DIN 5699
- Elimination of chain tension onto bucket and other parts

- Eliminating alternating load and thus avoiding fatigue fracture of shackle
- Supplied loose or pre-fitted with chain to form endless chain strand
- Suitable for chains to DIN 764/766 and works standard

Regarding high loads the chain pitch can be equal to the shackle pitch, regarding high capacity buckets we recommend the TS-L shackle.



Figure 10: HEKO chain shackle type TS

The TS type is recommended for use as a horizontal attachment, i.e. mostly buckets with side wall attachment. The forged distance plate incorporates an additional support on the chain wheel. Both toothed and toothless wheels can be used with the TS-Shackle.



Figure 11: HEKO chain shackle type TS-N

The TS-N type, though primarily used for vertical attachment, i.e. rear wall mounted buckets. It has the same properties as the TS-Shackle, the only difference being the use of a plain, fabricated distance plate which is more cost effective.



Figure 12: HEKO chain shackle type TS-L

The TS-L type is recommended for vertical attachment and high turning moments as imposed by wider and deeper buckets, i.e. high capacity buckets, and buckets over 630 mm width. An extended distance plate provides an additional support and extends the supporting centres over three chain pitches. The additional support ensures smoother operation under high loads and reduces wear. Due to the higher load capability, chain and shackle pitch can be the same even with high capacity buckets. The TS-L Shackle only benefits a vertical bucket attachment.

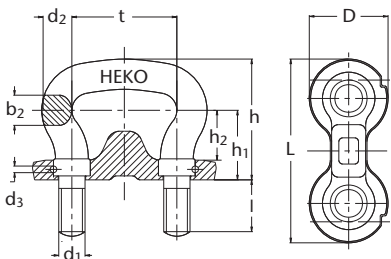


Figure 13:  
HEKO shackle type TS

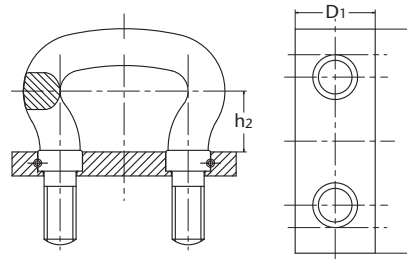


Figure 14:  
HEKO shackle type TS-N

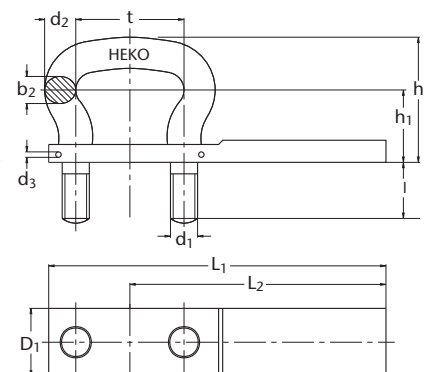


Figure 15:  
HEKO shackle type TS-L



**Table 4: Dimensions and qualities of HEKO shackle type TS, TS-N and TS-L**

pitch t/mm	to suit chain, nominal diameter		DIN	weight kg/each complete		dimensions in mm										HEKO quality hardened (0,14 x d) HEKO 6 MBK (kN)	
	d/mm			TS	TS-L	b <sub>2</sub>	d <sub>2</sub>	d <sub>3</sub>	d <sub>1</sub>	h	h <sub>1</sub>	D	L	L <sub>1</sub>	L <sub>2</sub>		l
45	13		764/766	0,53	0,86	14	14	5	M 12	64,5	40,5	37	75	150	112,5	26	106
56	16	762/764/766/WN	762/764	0,70	1,20	16	16	5	M 14	68	40	45	95	190	142,5	28	160
63	18		764/766	1,00	1,60	18	18	5	M 16	74	43	50	110	210	155	34	220
70	20	762/764/766	764	1,45	2,20	20	20	5	M 20	83	48	55	120	235	175	37	280
80	23	764/766/WN	764	1,85	3,10	23	23	5	M 20	92	53	60	130	265	170	37	360
91	26	764/766/WN	764	2,70	4,30	26	26	6	M 24	104	60	70	155	300	222,5	42	450
105	30	764/766/WN	764	3,90	6,20	30	30	6	M 24	118	68	80	165	345	262,5	42	630
126	34	WN	764/766	6,10	9,70	35	35	8	M 30	139	81	85	200	415	315	66	860
136	39	764/766	764	7,60	11,60	39	38	8	M 36	152	88	90	220	450	340	79	955
147	44	764/766	764	9,00	13,60	40	40	8	M 36	162	93	95	230	480	365	79	1160

MBK = min. breaking load, t = pitch, d = diameter Chain pitch and shackle pitch must be the same when using toothed chain wheels  
Toothless wheels may be used with un-matching chain and shackle pitch.

### 3.3 Endless chain system type TS, TS-N and TS-L



**Figure 16:**  
HEKO endless chain systems with shackle type TS, -TS-N and -TS-L

A further advantage of HEKO's endless chain strands is that toothed wheels are not required when the chain load provides sufficient friction grip, which applies in most cases.

#### Advantages of HEKO endless chain strands

- Pre-assembled chain strands in lengths to suit client's requirements
- Minimised erection time as complete strands can be pulled into the elevator
- Easy dis-assembly/shortening as split pins can be removed quickly
- Chain locks are not required
- Full load can be applied to the strands without attaching buckets

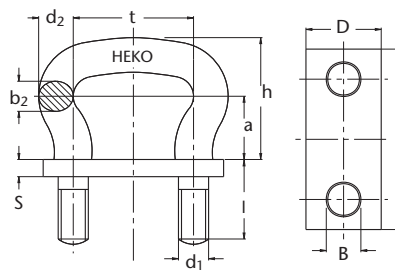
Increased service life as well as reduced investment and operation costs result. Correct selection of components, fitting and operation can eliminate chain slip in most cases, without excess tensioning via the idling wheel.



**Figure 17:**  
quick and simple assembly of a HEKO endless chain strand

The increased contact area provided, after the initial running-in period by the chain and shackle, leads to reduced wear when compared to other types of attachments.

## 3.4 Chain shackles to type DIN 5699 and type DIN 745



- Simple to fit
- For chain to DIN 764/766 and works standard
- Suitable for toothed wheels with equal chain pitch, otherwise use toothless wheels
- Shackles must only be used with distance plate and safety element to secure nut

Figure 18:  
HEKO shackle to type DIN 5699

Table 5: Dimensions and qualities of HEKO shackles to DIN 5699

pitch t/mm	to suit chain, chain wheel		weight kg/each shackle with nuts	plate	chain shackles dimensions in mm										HEKO qualities induction hardened		
	toothed d/mm	toothless d/mm-DIN			b <sub>2</sub>	d <sub>2</sub>	d <sub>1</sub>	h	a	l	L	D	S	B	HEKO41 MBK (kN)	HEKO5 MBK (kN)	
35	10 x 35	10-764	10-766	0,14	0,07	10	12	M 10	43	23	25	65	30	5	10,5	54	68
45	13 x 45	10/13-764	13-766	0,26	0,08	13	15	M 12	53	28	30	75	30	5	13	88	110
56	16 x 56	13/16-764	16-766	0,43	0,17	16	18	M 14	64	34	35	95	40	6	15	129	162
63	18 x 63	16/18-764	16/18-766	0,63	0,20	18	21	M 16	71	37	40	110	40	6	17	170	213
70	20 x 70	18/20-764	18/20-766	0,97	0,25	20	23	M 20	80	42	45	120	50	6	21	207	259
80	23 x 80	20/23-764	20/23-766	1,26	0,28	23	26	M 20	89	47	45	130	50	6	21	269	337
91	26 x 91	23/26-764	23/26-766	1,85	0,50	26	29	M 24	99	52	55	150	60	8	25	339	424
105	30 x 105	26/30-764	26/30-766	2,50	0,56	30	34	M 24	114	60	55	165	60	8	25	458	574
126	36 x 126	30/36-764	30/36-766	4,25	1,00	36	40	M 30	134	71	65	200	70	10	31	646	810
136	39 x 136	36/39-764	36/39-766	6,48	1,46	39	44	M 36	146	76	75	220	80	12	37	771	950
147	42 x 147	39/42-764	39/42-766	7,08	1,53	42	47	M 36	157	81	75	230	80	12	37	887	1110

MBK = min. breaking load, t = pitch, d = diameter, chain pitch and shackle pitch must be the same when using toothed chain wheels, regarding toothless wheels the shackle size may be bigger than the chain size. Remark Page 34. Tolerances as per table 3

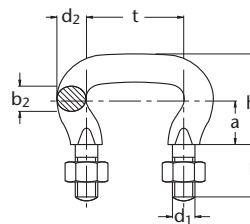


Figure 19:  
HEKO shackle to type DIN 745

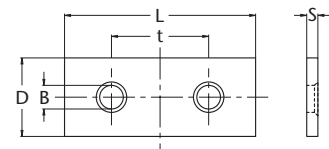


Figure 20:  
HEKO distance plate for shackle to type  
DIN 5699 and DIN 745

Table 6: Dimensions and qualities of HEKO shackles to DIN 745

pitch t/mm	to suit chain, chain wheel		weight kg/each shackle with nuts	plate	chain shackles dimensions in mm										HEKO qualities induction hardened		
	toothed d/mm	toothless d/mm-DIN			b <sub>2</sub>	d <sub>2</sub>	d <sub>1</sub>	h	a	l	L	D	S	B	HEKO41 MBK (kN)	HEKO5 MBK (kN)	
45	13 x 45	10-764	10-766	0,19	0,08	11,5	14	M 10	40	20	25	75	30	5	10,5	76	98
56	16 x 56	13/16-764	13-766	0,39	0,17	15	18	M 12	50	25	32	95	40	6	13	115	149
63	18 x 63	16/18-764	16-766	0,67	0,20	18	21	M 16	60	30	40	110	40	6	17	145	188
70	20 x 70	18/20-764	18/20-766	1,03	0,25	20	23	M 20	68	34	45	120	50	6	21	179	232
80	23 x 80	20/23-764	20/23-766	1,26	0,28	23	26	M 20	74	37	45	130	50	6	21	237	307
91	26 x 91	23/26-764	23/26-766	2,03	0,50	26	29	M 24	86	43	55	150	60	8	25	303	393
105	30 x 105	26/30-764	26/30-766	2,60	0,56	30	34	M 24	100	50	55	165	60	8	25	403	523
126	36 x 126	30/36-764	30/36-766	4,42	1,00	36	40	M 30	118	59	70	200	70	10	31	580	753
147	42 x 147	36/39-764	36/39-766	6,07	1,10	42	46	M 30	136	68	70	220	70	10	31	790	1025
147	42 x 147	39/42-764	39/42-766	7,33	1,53	42	46	M 36	136	68	85	230	80	12	37	790	1025

MBK = min. breaking load, t = pitch, d = diameter, chain pitch and shackle pitch must be the same when using toothed chain wheels, regarding toothless wheels the shackle size may be bigger than the chain size. Remark Page 34. Tolerances as per table 3

## 3.5 Chain shackle type S

- Simple to fit
- For chain to DIN 764/766 and works standard
- Suitable for toothed wheels with equal chain pitch, otherwise use toothless wheels
- Shackles must only be used with distance plate and safety element to secure nut

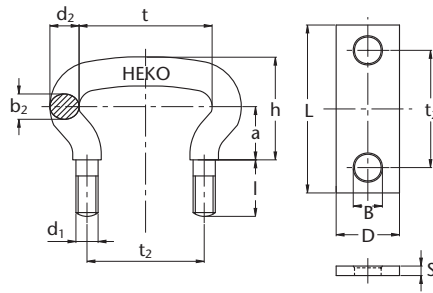


Figure 21:  
HEKO chain shackle type S



Table 7: Dimensions and qualities of HEKO shackles type S

pitch t/mm	to suit chain, DIN 764		weight kg/each shackle plate with 2 nuts	chain shackles dimensions in mm												HEKO quality induction hardened HEKO41 MBK (kN)
	DIN 766 d x t/mm	DIN 766 d x t/mm		t <sub>2</sub>	b <sub>2</sub>	d <sub>2</sub>	d <sub>1</sub>	h	a	l	L	D	S	B		
75	13 x 45	13 x 36	0,30	0,19	65	15	15	M 12	50	25	30	105	40	6	13	160
90	16 x 56	16 x 45	0,54	0,21	80	18	18	M 16	60	30	35	120	40	6	17	170
120	20 x 70	20 x 56	1,11	0,43	100	22	25	M 20	78	40	45	150	50	8	21	340
140	23 x 80	23 x 64	1,80	0,62	120	25	29	M 24	88	45	50	180	60	8	25	380
150	26 x 91	26 x 73	2,21	0,77	130	28	31	M 24	98	50	55	190	70	8	25	430
180	30 x 105	30 x 84	3,89	1,26	150	34	37	M 30	119	60	70	220	80	10	31	600
220	36 x 126	36 x 101	6,41	1,84	180	40	45	M 30	144	70	70	250	100	10	31	730
240	39 x 136	39 x 109	8,47	2,43	200	45	50	M 36	165	80	75	280	100	12	37	840
250	42 x 147	42 x 118	10,30	3,30	210	48	54	M 36	176	85	80	310	120	12	37	930

MBK = min. breaking load, t = pitch, d = diameter, other dimensions and executions on request

## 3.6 Special chain shackles type R

HEKO manufactures different shackle attachments to client's requirements. There is a huge stock of different executions and dimensions. The mentioned type R is available in two sizes, type 481 with 99 mm pitch for chain 13 x 45, type 482 N with 95 mm pitch for chain 18 x 63. The shackles are made of heat treatable steel with induction hardened contact areas.

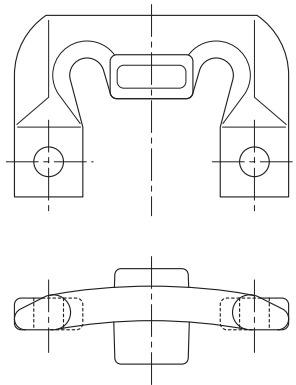


Figure 22:  
HEKO spezial chain shackle type R

## 3.7 Nuts and safety elements

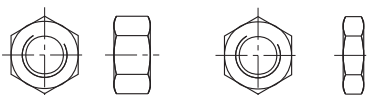


Figure 23: Hexagon nut to DIN 555/934 and half nut to DIN 439/936

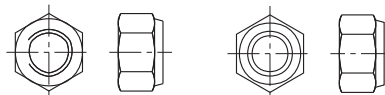


Figure 24: Self-locking nut with Nylon insert to DIN 985N and metallic self-locking nut to DIN 980V

A secure attachment of buckets is essential for prolonged smooth operation. Suitable safety elements are therefore essential and beside is a small selection which can be provided, others on request.

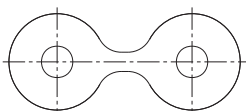


Figure 25: Safety sheet

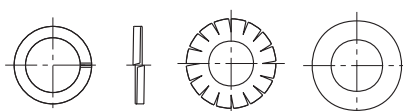


Figure 26: Spring washer to DIN 127, toothed locking washer and washer to DIN 125

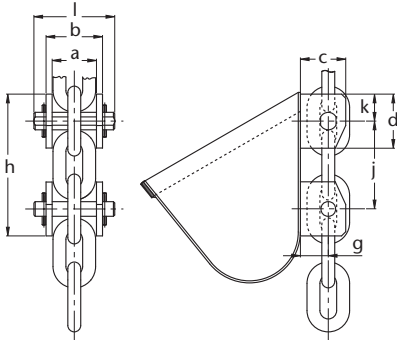
### 3.8 Plug-in bucket attachment type ST and chain locks type HF/HR and HV



**HEKO plug-in attachment for buckets**

- Variable bucket centres
- Improved bucket support compared to DIN-Shackle through larger support centres

- Endless chain strands with chain locks
- Suitable only with toothed wheels
- Requires chain locks and idling wheels with bucket guide discs



**Figure 27:**

**HEKO plug-in connector type ST**

**Parts can be supplied pre-assembled or loose**

The Plug-In attachment type ST consists of:

- 2x4 pieces side brackets with hardened holes

**Table 8: Dimensions for HEKO plug-in attachment type ST**

nominal dia. x pitch, dxt/mm	dimensions in mm									
	a	b	c	d	g	h	j	k	l	
14 x 50	49	65	55	65	30	150	100	25	93	
16 x 64	58	78	65	80	40	190	128	32	110	
19 x 75	68	90	75	95	40	230	150	40	130	
22 x 86	75	105	85	110	45	260	172	45	160	
26 x 100	92	122	100	120	50	290	200	45	170	
30 x 120	108	138	125	140	60	340	240	50	190	
34 x 136	120	150	130	155	65	380	272	55	210	
38 x 144	135	171	145	170	70	400	288	58	240	

t = pitch, d = diameter

- 2 support pins – flat, inclusive of split pin
- 2 support pins – round, inclusive of split pin, case hardened

**Fitting suggestions:**

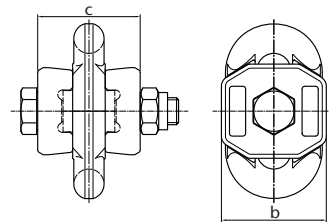
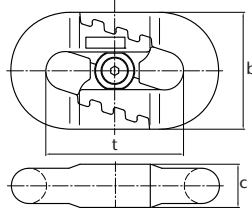
Line-up brackets so that the holes are in line and weld brackets to the buckets using a suitable electrode.



**Figure 28: Chain lock type HF**

Chain locks type HF/HR and HV are used for connecting longer chain strands. These chain locks have the same physical properties to those of the corresponding chain.

Assembly of 2 components is simple as the chain only needs to be slacked slightly. These chain locks should only be installed in vertical position.



**Table 9: Chain lock type HF/HR and HV**

to suit chain, nominal diameter x pitch d x t/mm	dimensions/mm height b	width c	weight kg/each	type
14 x 50	47	52	0,6	HV
16 x 64	56	18,5	0,5	HR
16 x 64	57	61	1,1	HV
19 x 75	66,5	23	0,8	HR
19 x 75	70	72	2,0	HV
22 x 86	77	26	1,9	HF
22 x 86	79	77	2,8	HV
26 x 100	89	29	2,4	HF
26 x 100	90	88,5	4,6	HV
30 x 120	107	36	3,2	HF
30 x 120	105	105	8,1	HV
34 x 126	117	40	4,2	HF
34 x 136	117	40	4,2	HF
38 x 144	133	45	5,2	HF



**Figure 29: HEKO chain lock type HV**

Suitable chain wheels as per page 27

## 4.0 HEKO chain locks

### 4.1 Chain locks type B and type D

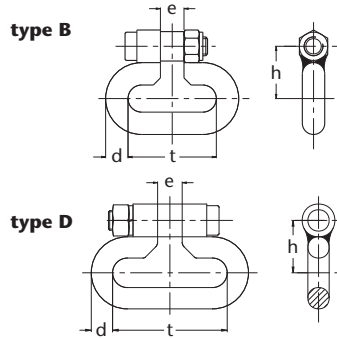


Figure 30: Chain locks type B with welded nut and type D with loose nut.

HEKO chain locks type B and type D are fabricated by welding. These chain locks are supplied complete with head cup screws to DIN 6912, grade 8.8. These chain locks are suitable for use with wheels with pocket teeth and projecting teeth. Normally these chain locks are installed horizontally, but special designs also allow vertical installation. Their material quality is matched to that of the chain.

Table 10: Sizes and qualities of HEKO chain locks type B und type D

to suit chain, nominal diameter x pitch d x t/mm	DIN chain	dimensions in mm		weight kg/each	head cup screw DIN 6912 8.8	HEKO quality, MBK (kN) <sub>1</sub> hardened contact area qualities					
		e	h			HEKO 280 E	HEKO 21	HEKO 210 E	HEKO 400 E	HEKO 5	HEKO 350 E
10 x 35	764	12	24	0,10	M 10	44	39	33	63	58	55
13 x 45	764	15	30	0,20	M 10	74	66	56	106	98	93
16 x 56	764	18	37	0,35	M 14	112	100	84	160	148	140
18 x 63	764	20	41	0,50	M 14	142	127	107	204	188	178
20 x 70	764	22	45	0,75	M 16	175	157	132	251	232	220
23 x 80	764	25	52	1,10	M 20	232	207	174	332	307	290
26 x 91	764	28	59	1,60	M 20	298	265	223	425	392	371
30 x 105	764	33	69	2,60	M 24	395	353	296	565	523	494
36 x 126	764	39	84	4,45	M 30	570	508	428	814	753	712

1) Other dimensions and qualities on request, tolerance -10% /HEKO 400E -20%, MBK = min. breaking load

### 4.2 Chain lock type E

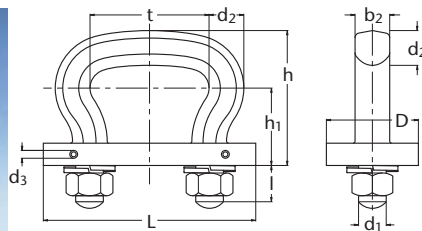


Figure 31: HEKO chain lock type E

HEKO chain locks type E are fabricated for heavy duty applications. Easy to fit and with double security by means of the use of nuts and split pins. Suitable for use with pocket toothed and projecting toothed wheels, as well as in vertical and horizontal position.

Table 11: Sizes and qualities of HEKO chain locks type E

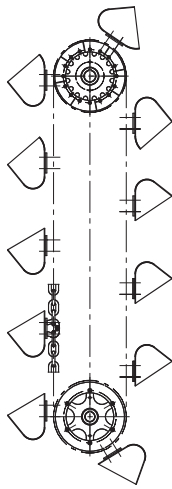
pitch t/mm	to suit chain, nominal diameter x pitch/DIN	weight kg/each	dimensions in mm								split pin to DIN 94 <sub>1</sub>	HEKO quality hardened HEKO 6 MBK (kN)
			b <sub>2</sub>	d <sub>2</sub>	d <sub>3</sub>	d <sub>1</sub>	h	h <sub>1</sub>	D	L		
45	13 x 45 / 764	0,53	14	14	5	M 12	64,5	40,5	37	75	5 x 30	106
56	16 x 56 / 764	0,70	16	16	5	M 14	68	40	45	95	5 x 36	160
63	18 x 63 / 764	1,00	18	18	5	M 16	74	43	50	110	5 x 40	220
70	20 x 70 / 764	1,45	20	20	5	M 20	83	48	55	120	5 x 45	280
80	23 x 80 / 764	1,85	23	23	5	M 20	92	53	60	130	5 x 50	360
91	26 x 91 / 764	2,70	26	26	6	M 24	104	60	70	155	6 x 55	450
105	30 x 105 / 764	3,90	30	30	6	M 24	118	68	80	165	6 x 70	630
126	36 x 126 / 764	6,10	35	35	8	M 30	139	81	85	200	8 x 70	860
136	39 x 136 / 764	7,60	38	38	8	M 36	152	88	90	220	8 x 80	955
147	42 x 147 / 764	9,00	42	40	8	M 36	162	93	95	230	8 x 80	1160

1) tolerance -10%, MBK = min. breaking load, spring pin as DIN 1481 on request.

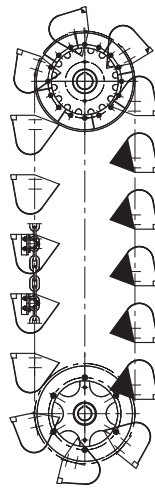


# 5.0 HEKO bucket elevator systems and their components

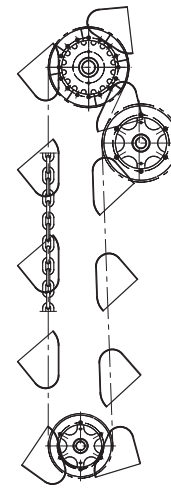
## 5.1 Scheme of chain bucket elevators



**Figure 32R:**  
Bucket elevator,  
rear wall mounted,  
for centrifugal  
discharge type



**Figure 33M:**  
Bucket elevator, side  
wall mounted, for  
gravity discharge  
type



**Figure 34S:**  
Bucket elevator, side  
wall mounted, with  
snub wheel, positive  
discharge type

**Table 12: Examples for chain and bucket elevators using HEKO elements, as shown in figure 31 R**

bucket b x a x s mm	P.C.D.	chain speed calc./min-max	to suit chain d x t	No. of links n	shackle pitch/DIN 745/5699	chain distance	TS shackle	bucket centres	bucket to volume l	DIN 15233 weight kg	capacity DIN/TS t/h
160 x 140 x 3	500	1	0,95-1,2	10 x 35	5	0,35	45	220	0,95	2,4	11/11
						7	0,49	290			8/8
						9	0,63	360			7/7
160 x 160 x 3	500	1	0,95-1,2	10 x 35	5	0,35	45	220	1,2	2,7	14/14
						7	0,49	290			11/11
						9	0,63	360			9/9
200 x 160 x 3 200 x 180 x 3 HL	500	1	0,95-1,2	13 x 45	5	0,79	56	281	1,5	3,2	14/15
						7	1,10	371			10/11
						9	1,42	461			8/9
250 x 180 x 3	630	1,05	0,95-1,2	16 x 56	5	1,46	63	343	2,4	5,6	19/20
						7	2,04	455			15/15
						9	2,62	567			12/12
250 x 200 x 4 250 x 200 x 4 HL	630	1,05	1,0-1,3	16 x 56	5	1,46	63	343	3	6,2	24/25
						7	2,04	455			18/19
						9	2,62	567			15/15
315 x 200 x 4 315 x 224 x 4 HL	630	1,1	1,0-1,3	18 x 63	5	2,05	70	385	3,75	7,2	28/29
						7	2,87	511			21/22
						9	3,69	637			17/17
400 x 224 x 4 400 x 250 x 4 HL	710	1,2	1,0-1,4	20 x 70	5	2,87	80	430	5,9	9,7	44/45
						7	4,02	570			33/34
						9	5,17	710			26/27
500 x 250 x 5 500 x 280 x 5 HL	800	1,25	1,0-1,4	23 x 80	5	4,40	91	491	9,3	16,4	63/65
						7	6,16	651			48/49
						9	7,92	811			38/39
630 x 280 x 5 630 x 315 x 5 HL	900	1,3	1,1-1,5	26 x 91	5	6,37	105	560	14,6	23,4	91/94
						7	8,92	742			69/70
						9	11,47	924			55/56
800 x 315 x 6 800 x 355 x 6 HL	1000	1,35	1,2-1,5	30 x 105	3	5,99	126	441	23,3	37,1	192/202
						5	9,98	651			130/134
						7	13,97	861			98/101
1000 x 355 x 6 1000 x 400 x 6 HL	1250	1,45	1,2-1,5	36 x 126	3	10,02	147	525	37,6	51,2	280/292
						5	16,70	777			189/194
						7	23,37	1029			143/146
1250 x 400 x 6 1250 x 450 x 6 HL	1250/1400	1,5	1,2-1,6	39 x 136	3	12,56	147	555	59,4	70,5	433/442
						5	16,70	827			290/294
						7	29,51	1099			218/221
1400 x 425 x 8	1400/1500	1,5	1,2-1,6	42 x 147	3	15,88	147	588	588	588	
						5	26,46	882			
						7	37,04	1176			
1600 x 450 x 8 1600 x 500 x 6 HL	1500	1,5	1,2-1,6	42 x 147	3	15,88	147	588	588	588	
						5	26,46	882			
						7	37,04	1176			

Degree of filling 75%, density of material 1,0 t/m<sup>3</sup>, volume = l, capacity = t/h, HL = high capacity bucket

The weight of the buckets correspond with the bucket execution finish C. For other centres you can also use chains to DIN 762, 766 and works standard. An example of a bucket elevator calculation refer to page 32. Regarding toothed wheels pitch of chain must be equal to shackle pitch.

- Elevator buckets to DIN and other dimensions
- Manufactured in a wide range of materials, including stainless steel, surface coating or rubber inserts
- Manufactured to HEKO standard or to bespoke requirements
- Buckets widths from 800 mm inclusive of stiffeners
- Suitable for all types of bucket attachments

Buckets are supplied for rear wall mounting with re-enforcing strip (Type L) or re-enforcing plate (Type M) or for side wall mounting (Type N).

Special requirements to suit customers can also be manufactured. The availability of high capacity buckets enables a considerable increase in throughput with minimal changes to the foot print of the elevator. When handling compacting material or large stones the addition of ripping teeth to the front of approx. 5 to 10 % of the buckets (Fig. 40) is recommended. Such teeth reduce the scooping forces, minimise the risk of the tensioning device lifting and thus prevent chain slip. The information below provides details of the most popular range of buckets.

DIN 15234			DIN 15235			HL		
volume l	weight kg	capacity DIN/TS t/h	volume l	weight kg	capacity DIN/TS t/h	volume l	weight kg	capacity DIN/TS t/h
1,5	2,6	18/19	1,5	2,6	18/19			
		14/15			14/15			
		11/11			11/11			
1,9	2,9	23/24	1,9	2,9	23/24			
		18/18			23/24			
		14/15			14/15			
2,4	3,4	23/24	2,4	3,4	23/24	4,1	4,6	39/41
		17/18			18/18			30/31
		14/14			14/14			24/25
3,7	4,4	30/31	3,7	4,4	30/31			
		23/23			23/23			
		18/18			18/18			
4,6	6,8	38/39	4,6	6,8	38/39	6,3	7,8	52/53
		28/29			28/29			39/40
		23/24			23/24			32/32
5,8	8	44/45	5,8	8	44/45	10	10,9	77/79
		33/34			33/34			58/59
		27/28			27/28			47/47
9,4	10,9	70/72	9,4	10,9	70/72	16,3	14,3	123/126
		53/54			53/54			93/94
		42/43			42/43			74/75
14,9	18,1	102/105	14,9	18,1	102/105	25,2	23,5	173/177
		76/78			76/78			130/133
		62/63			62/63			105/106
23,5	25,3	147/151	23,5	25,3	147/151	40,5	33,1	254/260
		111/113			111/113			192/195
		89/90			89/90			154/156
37,3	40,7	308/323	37,3	40,7	308/323	64,8	57,4	535/562
		208/215			208/215			363/375
		157/161			157/161			274/281
58,3	55,5	434/452	58,3	55,5	434/452	101,3	81,4	755/786
		293/301			293/301			510/525
		221/226			221/226			385/393
92	75,3	447/456	92	75,3	447/456	159,9	107	1166/1190
		450/456			450/456			783/794
		339/343			339/343			589/595
117	119,3	805	117		805			
		537			537			
		402			402			
150	137,8	1033	150		1033	256,3	141	1756
		688			688			1177
		516			516			883

For bucket connecting dimensions to DIN15236/4 see page 16. Re-enforcement and stiffening strips must not be welded continuously to avoid unnecessary stresses and possible distortion.

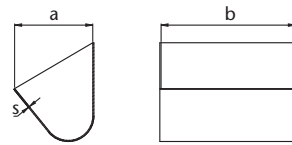


Figure 35: Bucket execution A – without re-enforcing rim

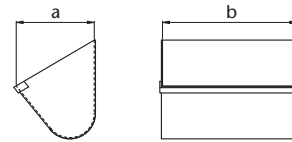


Figure 36: Bucket execution B – with front re-enforcing rim

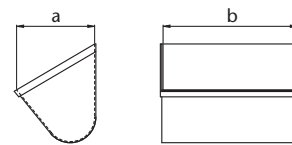


Figure 37: Bucket execution C – with re-enforcing rim on three sides

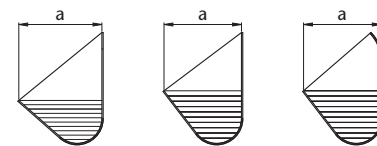


Figure 38: Elevator buckets to DIN 15233, 15234, 15235, (from left to right)

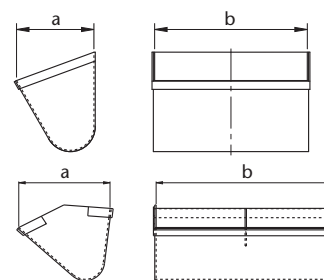


Figure 39: above left: high capacity bucket above right: gravity, central discharge bucket

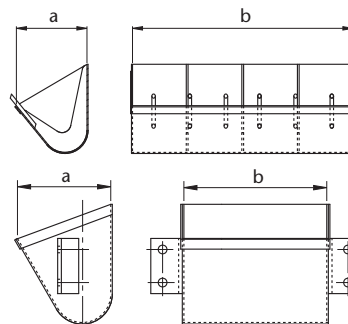
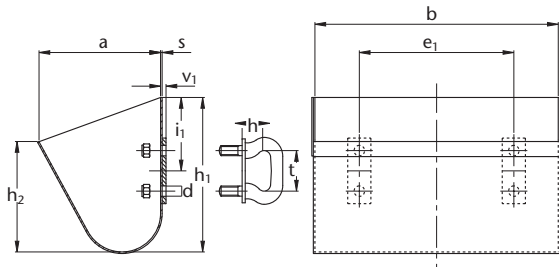
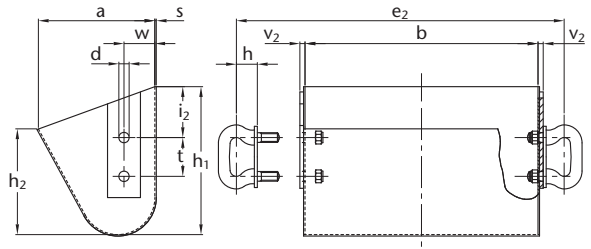


Figure 40: top bucket with teeth and middle web bottom – bucket with side brackets

## 5.2 Technical data for elevator buckets



**Figure 41:**  
Bucket with rear wall mounting  
type L



**Figure 42:**  
Bucket with direct side wall mounting  
type N

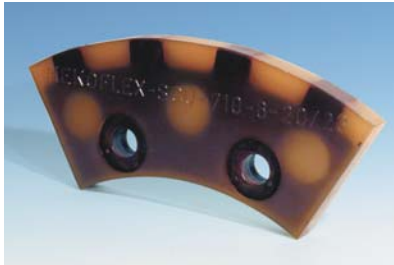
**Table 13: Dimensions for elevator buckets, bucket fastening to DIN 15236, page 4**

bucket b x a x s	DIN	h <sub>1</sub>	h <sub>2</sub>	t	d 5699 TS	d 745	h 5699 TS	h 745	e <sub>1</sub>	i <sub>1</sub>	v <sub>1</sub> 5699 TS	v <sub>1</sub> 745	e <sub>2</sub> 5699 TS	e <sub>2</sub> 745	i <sub>2</sub>	v <sub>2</sub>	w
160 x 140 x 3	15233	160	63	35	10,5		28		100	56	7		230	60	7	36	
	15234	180	95							67				67			
	15235	200	95	45	13	10,5	33	25		100	9	7	240	224	67		
160 x 160 x 3	15233	180	71	45	13	10,5	33	25	100	63	9	7	240	224	67	7	40
	15234	200	106							75				75			
	15235	224	106	56	15	13	40	31		112	12	10	254	236	75		
200 x 160 x 3	15233	180	71	45	13	10,5	33	25	125	63	9	7	280	264	67	7	40
	15234	200	106							75				75			
	15235	224	106	56	15	13	40	31		112	12	10	294	276	75		
200 x 180 x 3	HL	224	159	56	15	13	40	31	125	100	12	10	294	276	85	7	45
250 x 180 x 3	15233	200	80	56	15	13	40	31	160	71	12	10	344	326	75	7	45
	15234	224	118							85				85			
	15235	250	118	63	17	17	43	36		125	13	13	350	336	85		
250 x 200 x 4	15233	224	90	56	15	13	40	31	160	80	12	10	344	326	85	7	50
	15234	250	132							95				95			
	15235	280	132	63	17	17	43	36		140	13	13	350	336	95		
250 x 200 x 4	HL	250	175	63	17	17	43	36	160	110	13	13	350	336	95	7	50
315 x 200 x 4	15233	224	90	63	17	17	43	36	200	80	13	13	418	404	85	8,5	50
	15234	250	132							95				95			
	15235	280	132	70	21	21	48	40		140	14	14	428	412	95		
315 x 224 x 4	HL	280	198	63	17	17	43	36	200	125	13	13	418	404	106	8,5	56
400 x 224 x 4	15233	250	100	70	21	21	48	40	250	90	14	14	513	497	95	8,5	56
	15234	280	150							106				106			
	15235	315	150	80	21	21	53	43		160	14	14	523	503	106		
400 x 250 x 4	HL	315	229	80	21	21	53	43	250	150	14	14	523	503	118	8,5	63
500 x 250 x 5	15233	280	112	80	21	21	53	43	315	100	14	14	626	606	106	10	63
	15234	315	110							118				118			
	15235	355	170	91	25	25	60	51		180	17	17	640	622	118		
500 x 280 x 5	HL	355	253	91	25	25	60	51	315	170	17	17	640	622	132	10	70
630 x 280 x 5	15233	315	125	91	25	25	60	51	400	112	17	17	770	752	118	10	70
	15234	355	190							132				132			
	15235	400	190	105	25	25	68	58		200	17	17	786	766	132		
630 x 315 x 5	HL	400	287	105	25	25	68	58	400	190	17	17	786	766	150	10	80
800 x 315 x 6	15233	355	140	105	25	25	68	58	500	125	17	17	960	940	132	12	80
	15234	400	212							150				150			
	15235	450	212	126	31	31	81	69		224	17	17	986	962	150		
800 x 355 x 6	HL	450	320	126	31	31	81	69	500	220	17	17	986	962	170	12	90
1000 x 355 x 6	15233	400	160	126	31	31	81	69	630	140	17	20	1186	1162	150	12	90
	15234	450	236							170				170			
	15235	500	236	136	37		88			250	20		1200		170		
1000 x 400 x 6	HL	500	353	136	37		88		630	250	20		1200		190	12	100
1250 x 400 x 6	15233	450	180	136	37		88		800	160	20		1454		170	14	100
	15234	500	265							190				190			
	15235	560	265	147	37	37	93	80		280	20	20	1464	1438	190		
1250 x 450 x 6	HL	560	397	147	37	37	93	80	800	280	20	20	1464	1438	230	14	125
1400 x 425 x 8	15234	545	282	147	37	37	93	80	900	230	20	20	1614	1588	230	14	115
1600 x 450 x 8	15234	575	300	147	37	37	93	80	1000	250	20	20	1814	1788	250	14	125
1600 x 500 x 6	HL	630	449	147	37	37	93	80	1100	315	20	20	1814	1788	270	14	140

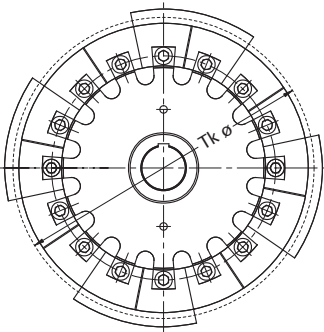
HL = High capacity bucket

## 6.0 HEKO chain wheels

### 6.1 Toothless chain wheels with „HEKOFLEX“ rim segments type RUH and type RUHS

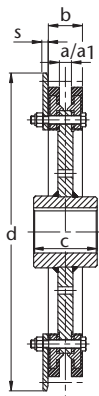


**Figure 43:**  
HEKOFLEX rim segment type RUHS with steel core, contact areas hardened



HEKOFLEX segmented rims are manufactured from Polyurethane, the excellent properties of which ensure a good service life. A Steel-Polyurethane combination is used for higher load applications which combines the higher load carrying capability of the steel core and improved friction grip of the Polyurethane. In addition to the improved friction grip of the

- Quiet running
- Also suitable as non-toothed drive wheels for short shaft centres due to improved friction grip



Polyurethane, larger loads can be accommodated thus improving the service life compared to the normal HEKOFLEX segments. HEKOFLEX rims can be used with operating temperatures up to 100° C.



**Figure 44:**  
HEKOFLEX rim segment type RUH with steel or cast iron core



**Figure 45:**  
HEKOFLEX sprocket wheel teeth with plastic chain bearing surface

Fitting instructions see page 34

**Table 14: Dimensions of HEKOFLEX plastic segments type RUH and RUHS**

P.C.D. chain wheel mm, Tkø	to suit chain nominal diameter d/mm	shackle pitch t/mm	dimensions in mm					number of segments each wheel	weight without chain guide kg/each	model reference
			a/a1	b	c	d	s			
400	13	45/56	18/20	72	80	430	10	12	35	SCU-400-6-13/16
500	13	45/56	18/20	73	100	535	10	12	50	SCU-500-13/16/18
630	16	56/63	20/23	79		535	10	12	90	SCU-630-16/18/20
	18	63/70	23/25	84	160	660	10	12		
	20	70/80	25/28	89		660	10	12		
710	20	70/80	25/28	98	160	750	15	12	140	SCU-710-6-20/23
	23	80/91	28/32	105		750	15	12		
800	23	80/91	28/32	111	160	850	15	12	200	SCU-800-6-23/26
	26	91/105	32/36	121		850	15	12		
900	26	91/105	32/36	128	190	950	15	16	290	SCU-900-8-26/30
	30	105/126	36/42	140		950	15	16		
1000	30	105/126	36/42	146	200	1040	20	16	340	SCU-1000-8-30/33/36
	33	126/136	40/45	153		1040	20	16		
	36	126/136	42/45	153		1040	20	16		
1250	36	126/136	42/45	159	220	1300	20	16	510	SCU-1250-8-36/39
	39	136/147	45/50	169		1300	20	16		

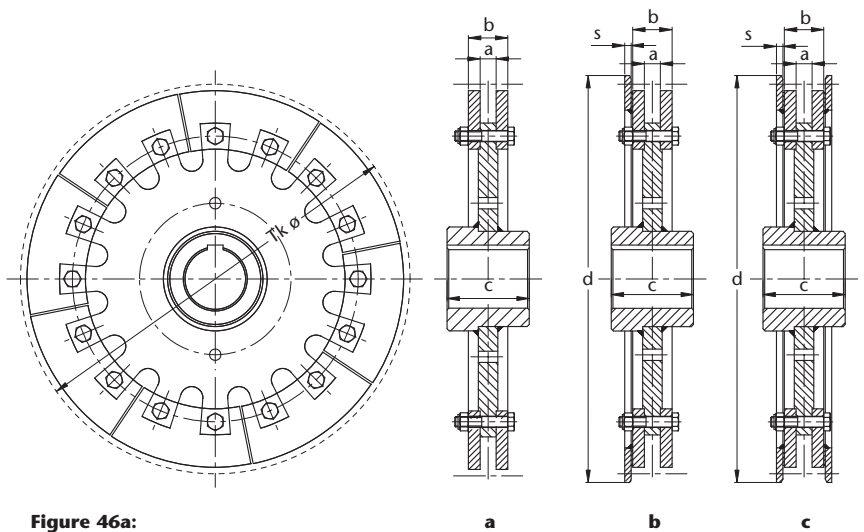
P.C.D./Tkø = pitch circle diameter, d = diameter, t = pitch, with side mounted shackle DIN 745 and other shackles, dimensional differences must be considered. We will be pleased to assist on applications with large shaft centres and throughputs.

## 6.2 Toothless chain wheels with replaceable steel rim segments type RUA



- Preferable for drive wheels  
high load capability
- Suitable for vertical and  
horizontal bucket attachments
- Complete with cut-outs to  
prevent product build-up in  
wheels

HEKO chain wheels type RUA are predominantly fitted as drive wheels. These wheels have a higher load capacity due to the large number of fixings which secure the segments. Hubs are manufactured from carbon steel and segments are fabricated from CrMo alloy steel. Segments are normally supplied with a tensile strength of 700 to 800 N/mm<sup>2</sup>, but this can be increased, on request, by heat treatment up to 1000-1400 N/mm<sup>2</sup>. Such treatment ensures good durability under extreme operating conditions. The chain wheels type RUA can be used with vertically and horizontally mounted shackles and other types of bucket attachments. The steel segments can also be retrofitted to cast iron or cast steel hubs. The cut-outs in the hub minimise the chance of material build-up within the wheel which could otherwise lead to chains coming off the wheels. All wheels are supplied with keyways or, on request, with taper lock bushes. In addition the hubs have holes for spacer bars to adjust for the correct chain centre distance. Segments can be supplied, on request, with chain guide at one or both sides. However, experience has shown that such guide is unnecessary for drive wheels in most cases.



**Figure 46a:**  
HEKO chain wheel type RUA, toothless,  
with replaceable steel segments

**Figure 46b:**  
HEKO chain wheel type RUA I, toothless,  
with replaceable steel segments and  
chain guide at one side

**Figure 46c:**  
HEKO chain wheel type RUA II, toothless,  
with replaceable steel segments and  
chain guide at both sides

**Table 15: Dimensions for toothless HEKO chain wheels with interchangeable steel segments type RUA**

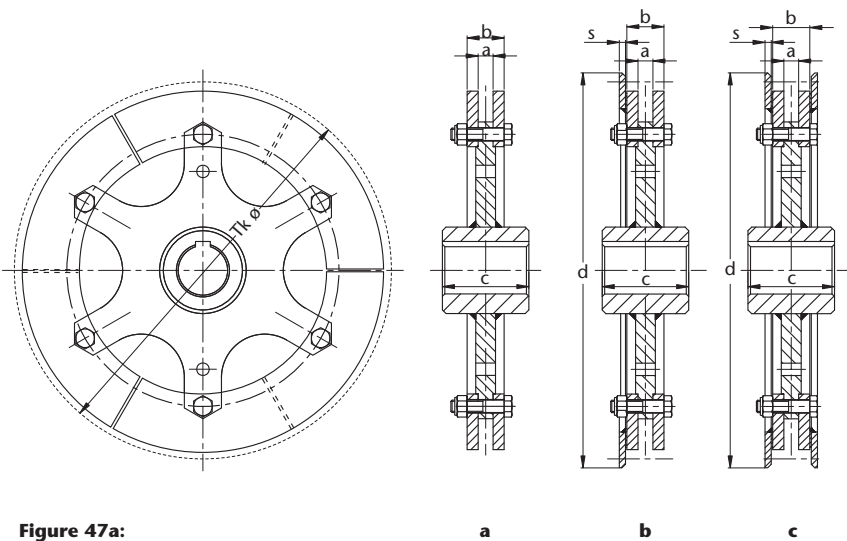
P.C.D. chain wheel mm, T <sub>k</sub> ø	to suit chain nominal diameter d/mm	shackle pitch t/mm	dimensions in mm					number of segments each wheel	weight without chain guide kg/each
			a	b	c	d	s		
400	10	35/45	15	35	80	420	12	12	40
	13	45/56	18	48	80	420	12	12	40
500	13	45/56	18	48	100	525	12	12	50
	16	56/63	21	51	100	525	12	12	62
630	16	56/63	21	51	160	650	12	12	81
	18	63/70	23	59	160	650	12	12	110
710	20	70/80	25	65	160	650	12	12	115
	20	70/80	25	65	160	750	12	12	165
800	23	80/91	28	68	160	850	15	12	220
	26	91/105	32	78	160	850	15	12	220
900	26	91/105	32	78	190	950	15	16	295
	30	105/126	36	96	200	1050	15	16	390
1250	30	105/126	36	96	220	1300	15	16	630
	36	126/136	42	112	220	1300	15	16	660
1400	39	136/147	45	125	240	1450	15	18	850
	42	147	48	128	260	1450	15	18	850
1500	42	147	48	128	260	1550	15	18	960

P.C.D./T<sub>k</sub>ø = pitch circle diameter, d = diameter, t = pitch, other dimensions and executions on request.

Fitting instructions see page 34



## 6.3 Toothless chain wheels with replaceable steel rim segments type RUU



**Figure 47a:**  
HEKO chain wheel type RUU, toothless with replaceable steel segments

**Figure 47b:**  
HEKO chain wheel type RUU I, toothless with replaceable steel segments and chain guide at one side

**Figure 47c:**  
HEKO chain wheel type RUU I, toothless with replaceable steel segments and chain guide at both sides

- Suitable as return and drive wheel, drive wheel for medium load capability
- Extra large cut-outs to prevent build-up inside the wheel, ideal for return idling wheels
- Suitable for vertical and horizontal bucket attachments

**Table 16: Dimensions for toothless HEKO chain wheels with replaceable steel segments type RUU**

P.C.D. chain wheel mm, $T_k \phi$	to suit chain nominal diameter d/mm	shackle pitch t/mm	dimensions in mm					number of segments each wheel	weight without chain guide kg/each
			a	b	c	d	s		
400	10	35/45	15	35	80	420	12	6	30
	13	45/56	18	48	80	420	12	6	30
500	13	45/56	18	48	100	525	12	6	45
	16	56/63	21	51	100	525	12	6	45
630	16	56/63	21	51	160	650	12	6	80
	18	63/70	23	59	160	650	12	6	85
	20	70/80	25	65	160	650	12	6	85
710	20	70/80	25	65	160	750	12	6	115
800	23	80/91	28	68	160	850	15	6	155
	26	91/105	32	78	160	850	15	6	220
900	26	91/105	32	78	190	950	15	8	260
1000	30	105/126	36	96	200	1050	15	8	340
1250	30	105/126	36	96	220	1300	15	8	530
	36	126/136	42	112	220	1300	15	8	530
1400	39	136/147	45	125	240	1450	15	8	805
	42	147	48	128	260	1450	15	8	840
1500	42	147	48	128	260	1550	15	8	960

P.C.D./ $T_k \phi$  = pitch circle diameter, d = diameter, t = pitch, other dimensions and executions on request.

HEKO chain wheels type RUU may be used as return idling wheels as well as drive wheels for medium load and up to 30m shaft centres. The large cut-outs in the hub are designed to prevent build-up of product inside the wheels and are therefore ideal for return idling wheels inside the elevator boot. Even material with larger particle size is pressed through the large cut-outs, otherwise this could lead to chains coming off the wheels. Hubs are manufactured from carbon steel and segments are fabricated from CrMo alloy steel. Segments are normally supplied with a tensile strength of 700 to 800 N/mm<sup>2</sup>, but this can be increased, on request, by heat treatment. These chain wheels can be used with vertically and horizontally mounted shackle and many other types of bucket attachments. All wheels are supplied with keyways or, on request, with taper lock bushes. In addition the hubs have holes for spacer bars to adjust for the correct chain centre distance. Segments can be supplied, on request, with chain guide at one or both sides. However, experience has shown that such discs are unnecessary for drive wheels.

Fitting instructions see page 34

## 6.4 Toothless chain wheel with replaceable hard cast iron segments type SUR, type KS and type KSE

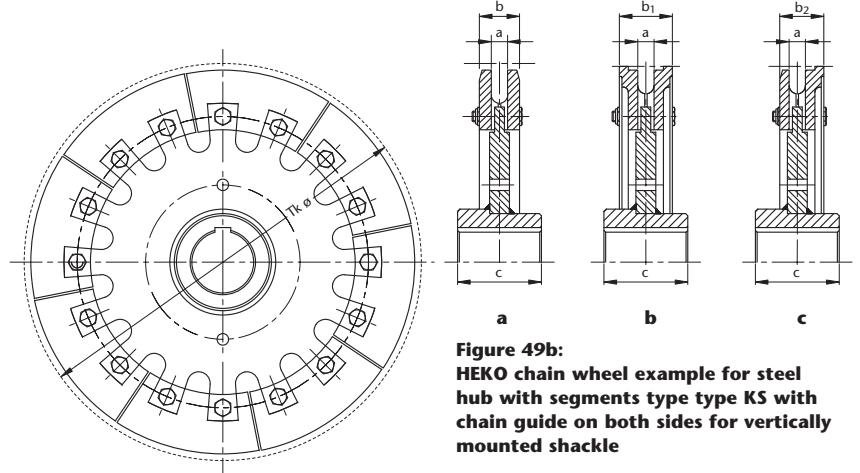


**Figure 48:**  
HEKO chain wheel example for cast iron hub with segments type KS

- Suitable for low loads and low abrasion
- Hubs made from cast iron also available with alloy steel segments

Chain wheels with segments type SUR, KS or KSE are designed for low and medium loads. Hubs are manufactured from carbon steel and segments are cast from hard wearing chilled iron. The small openings in the hub limits their use as return wheels in elevator boots as material might build up within the wheel groove. Higher loads can be achieved with HEKO chain wheels type RUA and RUU and better self-cleaning with wheels type RUU. Cast wheel rims are brittle and also susceptible to fractures caused by heavy knocks. Hubs are also available in grey cast iron (but without cut-out). Cast wheels are inexpensive and cost effective for less arduous applications. These chain wheels can be used with vertically and horizontally mounted shackles and other types of bucket attachments depending on the type of segment.

**Fitting instructions see page 34**



**Figure 49a:**  
HEKO chain wheel example for steel hub with segments type SUR without chain guide for vertically and horizontally mounted shackle

**Figure 49b:**  
HEKO chain wheel example for steel hub with segments type type KS with chain guide on both sides for vertically mounted shackle

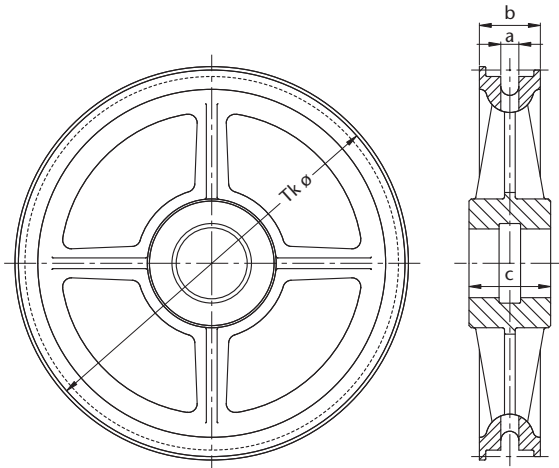
**Figure 49c:**  
HEKO chain wheel example for steel hub with segments type type KSE with chain guide at one side for horizontally mounted shackle

**Table 17: Dimensions for chain wheels with replaceable chilled cast iron segments type SUR, type KS and type KSE**

P.C.D. chain wheel mm, Tko	to suit chain d/mm	shackle pitch t/mm	dimensions in mm					number of segments each wheel	weight kg/each approx.		
			SUR a	KS b	KSE b1	b2	c		SUR	KS	KSE
400	13	45/56	18	47			100	12	29		
	16	56/63	22	66			100	12	38		
500	13	45/56	18	60	90	65	100	(12 SUR)8	51	60	55
	16	56/63	22	66	100	75	100	(12 SUR)8	53	60	55
630	20	70/80	28	80	118	91	100	(12 SUR)8	57	65	60
	16	56/63	22	66	120	75	160	12	103	130	120
710	20	70/80	28	80	130	97	160	12	105	135	125
	23	80/91	30	140	110	160	12	140	130		
	26	91/105	32		125	160	12	135			
	16	56/63	22	130	97	160	12	185	175		
800	20	70/80	28	80	130	102	160	12	165	190	180
	23	80/91	30	140	110	160	12	190	180		
	26	91/105	34	164	125	160	12	210	190		
	30	105/126	36		130	160	12	195			
900	16	56/63	22	132	160	12	250				
	20	70/80	26		101	160	12		230		
	23	80/91	30	90	140	110	160	12	221	255	235
	26	91/105	34	100	160	130	160	12	228	260	245
1000	30	105/126	36		130	160	16	250			
	16	56/63	20		75	190	16	300			
	20	70/80	26		102	190	16	310			
	23	80/91	30	145	190	16	335				
1250	26	91/105	34	100	170	129	190	16	293	345	320
	30	105/126	40	120	176	190	16	318	355		
	20	70/80	26		100	200	16	340			
	23	80/91	30	140	110	200	16	420	360		
1400	26	91/105	36	180	133	200	16	440	380		
	30	105/126	40	120	185	133	200	16	390	445	405
	36	126/136	46	135		200	16	420			
	26	91/105	32		138	220	16		625		
1500	30	105/126	40	120	185	133	220	16	643	705	645
	36	126/136	46	135	200	161	220	16	658	735	670
1600	39	136/147	46	145		220	16	703			
	36	126/136	46	135		240	18	770			
1500	39/42	136/147	46	145		240	18	850			
	36	126/136	46	135		240	18	920			
1600	39/42	136/147	46	145		240	18	980			
	36	126/136	46	135		260	20	1080			
	39/42	136/147	46	145		260	20	1150			

P.C.D./Tko = pitch circle diameter, d = diameter, t = pitch

## 6.5 Toothless chain wheels, one piece, in grey cast iron, type GGB



**Figure 50:**  
HEKO chain wheel type GGB, toothless,  
one piece, in grey cast iron, type GGB

- Suitable for low loads,  
predominantly return idling  
wheels
- Suitable for vertical bucket  
attachments only

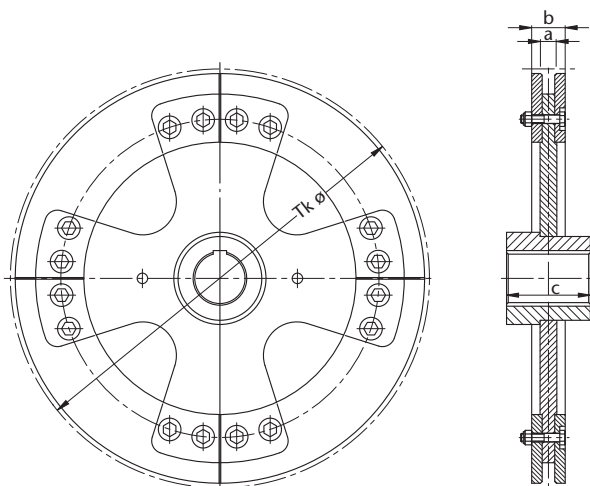
**Table 18: Dimensions for toothless chain wheels, one piece, in grey cast iron, type GGB**

P.C.D. chain wheel mm, Tkø	to suit chain nominal diameter d/mm	shackle pitch t/mm	dimensions in mm			weight kg/each approx.
			a	b	c	
400	13	45	18	70	100	30
	16	56/63	22	90	100	32
500	13	45/56	18	90	100	48
	16	56/63	22	90	100	48
630	16	56/63	22	110	160	95
	20	70/80	28	130	160	115
710	20	70/80	28	130	160	150
	23	80/91	30	140	160	200
800	26	91/105	34	140	160	200
	26	91/105	34	170	190	290
1000	30	105/126	40	180	200	370
1250	30	105/126	40	190	220	530
	36	126/136	46	190	220	530

P.C.D./Tkø = pitch circle diameter, d = diameter, t = pitch

Toothless chain wheels type GGB are only suitable for applications with low loads and for material with low abrasiveness. These low cost wheels are more frequently fitted as return idlers on which the openings minimise product build-up within the wheel grooves. The chain wheels have a chain guide.

## 6.6 Toothless chain wheels with replaceable steel rim segments type RUR



**Figure 51:** Toothless chain wheel with replaceable steel rim segments type RUR

The chain wheels can be used as drive wheels as well as return wheels. Large relief slots prevent material built-up between the chain wheel rims. The chain wheel hubs are manufactured from carbon steel and segments are fabricated from CrMo alloy steel. On request the rim segments can be heat treated up to 1000-1400 N/mm<sup>2</sup> for higher loads. Dimensions as per type RUU page 19.

**Fitting instructions see page 34**

## 6.7 Toothless chain wheels with replaceable steel rim segments type RUP



- Suitable as drive and idling wheel
- Suitable for vertical and horizontal shackle attachment
- Supplied with segments in 90° (quarters) or 180° (halves) execution
- Suitable for heavy load applications
- 90° segments can be exchanged with chain resting on the wheel

HEKO chain wheels Type RUP are supplied primarily with 90° segment to ease replacement, but 180° segments may be supplied on request. Instead of cast iron, HEKO manufactures the segments from CrMo alloy steel, which substantially increases the service life. Segments are normally supplied with a tensile strength of 700 to 800 N/mm<sup>2</sup>, but this can be increased, on request, by heat treatment up to 1000-1400 N/mm<sup>2</sup>. Such treatment ensures good durability under extreme operating conditions. These chain wheels can be used with vertically and horizontally mounted shackles and many other types of bucket attachments. The steel segments can also be retrofitted to cast iron or cast steel hubs. The cut-outs in the hub minimise the chance of material build-up within the

Fitting instructions see page 34

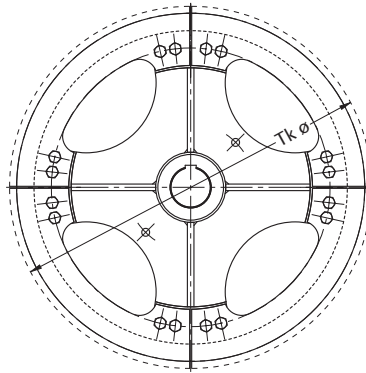


Figure 52: HEKO chain wheel type RUP with replaceable steel rim segments

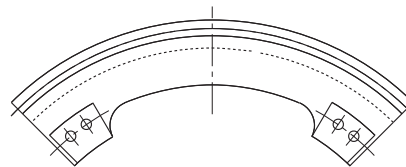


Figure 53: Replaceable 90° segment (quarter) for HEKO chain wheel type RUP

wheel, which could otherwise lead to chains coming off the wheels. All wheels are supplied with keyways or, on request, with taper lock bushes. In addition the hubs have holes for spacer bars to adjust for the correct

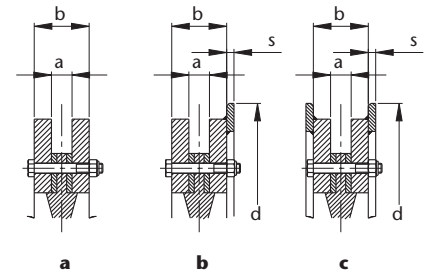


Figure 52a: HEKO chain wheel type RUP, toothless with replaceable steel rim segments

Figure 52b: HEKO chain wheel type RUP I, toothless with replaceable steel rim segments and chain guide at one side

Figure 52c: HEKO chain wheel type RUP II, toothless with replaceable steel rim segments and chain guide at both sides.

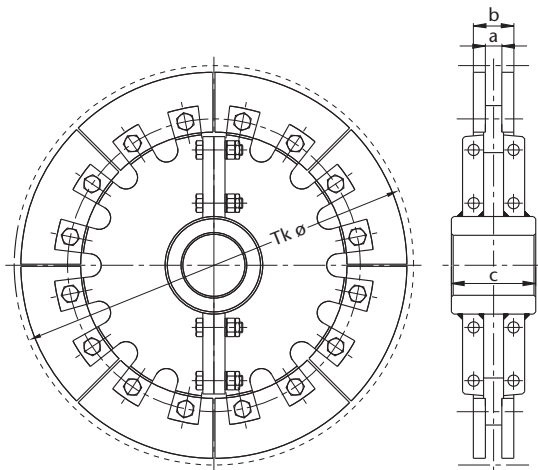
chain centre distance. Segments can be supplied, on request, with chain guide at one or both sides. However, experience has shown that such chain guides only required for return wheels.

Table 19: Dimensions for chain wheels type RUP, type RUP I, type RUP II

P.C.D. chain wheel	to suit chain shackle		bucket width	dimensions in mm					number of segments each wheel 90° Seg.	weight without chain guide kg/each
	nominal diameter	t/mm		a	b	c	d	s		
mm, Tkø	d/mm	t/mm								
500	16	63	160				150	12	8	50
			200					8	8	55
630	18	70	250	23	57	150		12	8	85
			315	23				8	8	90
710	20	80	400	33	74		734	12	8	115
820	23	91	500	38	90		845	15	8	175
930	26	105	630	44	96	180	960	15	8	290
1000	30	126	800			200		15	8	350
1130	30	126	1000	48	120	200	1164	15	8	410
1250	36	147	1250	62	150	250	1290	15	8	540
1340	36	147	1400				1385	15	8	760

P.C.D./Tkø = pitch circle diameter, d = diameter, t = pitch, other dimensions and executions on request

## 6.8 Toothless chain wheels, in steel with split hub, type RUG

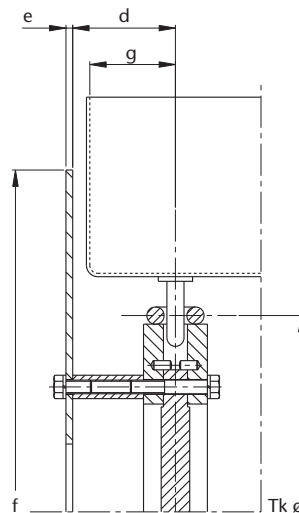


**Figure 54:**  
HEKO toothless chain wheel type RUG, in steel, with split steel hub

- Suitable as drive and idling wheels
- For steel and cast iron segments
- Can be supplied to suit client's dimensional requirements

HEKO chain wheels type RUG are supplied with toothless steel segments. Such wheels have the advantage of being assembled to shafts already in position.

## 6.9 Bucket guide disc for toothless chain wheels, Type RUB



**Figure 55:**  
HEKO bucket guide disc type RUB mounted on toothless chain wheel



- Providing an additional bucket guide in the elevator boot
- Discs can be supplied in special executions

**Table 20: Dimensions for HEKO guide discs type RUB**

P.C.D. of chain wheel mm, Tkø	to suit chain, chain dia. d/mm	shackle pitch up to t/mm	bucket width	dimensions in mm				weight kg/each approx.
				f	b	e	g	
500	10	45	160	650	46	6	30	12
	13	56	200	650	53	6	37,5	12
630	16	63	250	840	65	8	45	27
	18	70	315	840	77	8	57,5	27
710	20	80	400	980	95	8	75	39
800	23	91	500	1100	115	10	92,5	59
900	26	105	630	1250	140	12	115	100
1000	30	126	800	1380	180	12	150	119
1250	36	136	1000	1700	215	15	215	185

P.C.D./Tkø = pitch circle diameter, d = diameter, t = pitch, other dimensions and executions on request

HEKO bucket guide discs are manufactured from carbon steel and are bolted to the outward facing side of the chain wheel.

Bucket guide discs are usually fitted to return idling wheels in the elevator boot to restrict bucket movement, usually in applications where side forces on the buckets are expected. Such guide discs are an alternative to fixed guide rails attached to the side wall of the boot. We recommend that elevator inlets are designed to centralise the feed into the bucket. Guide discs may be retrofitted to existing cast or steel wheels.

**Fitting instructions see page 34**



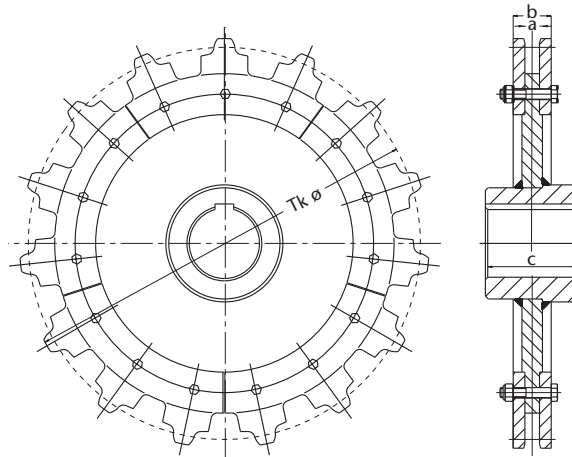
## 6.10 Chain wheels with pocket teeth, in steel, with replaceable rim segments type GTA



- Suitable as drive wheels
- Excellent service life due to hardened contact surfaces
- Suitable for vertical bucket attachments

HEKO drive wheels with pocket teeth type GTA are renowned for their trouble-free operating characteristics and long service life. The replaceable toothed rims are manufactured from alloy steel with teeth hardened (contact areas) to reduce wear. These wheels can be used with vertical shackles and other types of attachments. Wheels are supplied with keyway or taper lock bushes, the latter on request. In addition, the hubs have holes for spacer bars to adjust for the correct chain centre distance.

Toothed wheels are fitted to eliminate chain slip, usually caused when toothless wheels provide insufficient friction grip, i.e. short shaft centres.



**Figure 56:**  
HEKO chain wheel type GTA, with replaceable pocket teeth, welded hub

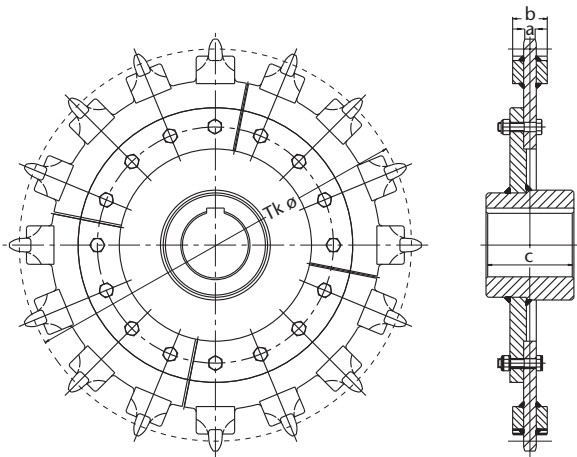
**Table 21: Dimensions for chain wheels type GTA**

P.C.D. chain wheel mm, T <sub>k</sub> ø	to suit chain nominal diameter x pitch, d x t/mm	DIN	number of teeth	dimensions in mm			weight kg/each approx.
				a	b	c	
402	10 x 35	764	18	15	45	80	30
446			20	15	45	80	33
513			23	15	45	80	35
402	13 x 45	764	14	18	48	100	40
516			18	18	48	100	60
631			22	18	48	100	70
500	16 x 56	764	14	21	57	130	70
643			18	21	57	130	105
714			20	21	57	130	135
523	18 x 63	764	13	23	63	140	75
643			16	23	63	140	110
723			18	23	63	140	140
625	20 x 70	764	14	25	65	150	105
714			16	25	65	150	150
803			18	25	65	150	180
715	23 x 80	764	14	28	78	150	175
816			16	28	78	150	210
918			18	28	78	150	255
697	26 x 91	764	12	32	82	180	190
813			14	32	82	180	230
928			16	32	82	180	310
804	30 x 105	764	12	36	96	200	240
938			14	36	96	200	350
1071			16	36	96	200	420
965	36 x 126	764	12	42	112	220	380
1125			14	42	112	220	520
1285			16	42	112	220	690
1042	39 x 136	764	12	46	116	240	520
1215			14	46	116	240	630
1388			16	46	116	240	780
1126	42 x 147	764	12	50	130	250	620
1313			14	50	130	250	820
1406			15	50	130	250	950

P.C.D./T<sub>k</sub>ø = pitch circle diameter, d = diameter, t = pitch, other dimensions and executions on request. Also available for chains as per DIN 766 and other standards. The chain pitch must be equal to the shackle pitch.

Fitting instructions see page 34

## 6.11 Chain wheels with projecting teeth, in steel, with replaceable rim segments, type GIA



**Figure 57:**  
Chain wheel type GIA, with replaceable projecting teeth, welded hub.



- Suitable as drive wheels for medium duty applications
- Excellent service life due to hardened contact surfaces
- Suitable for horizontal bucket attachments

**Table 22: Dimensions for chain wheels Typ GIA with replaceable projecting teeth and welded hub**

P.C.D. chain wheel mm, TK ø	to suit chain nominal diameter x pitch, d x t/mm	DIN	number of teeth	dimensions in mm			weight kg/each approx.
				a	b	c	
402	10 x 35	764	18	11	35	80	20
446			20	11	35	80	28
513			23	11	35	80	38
402	13 x 45	764	14	15	45	100	30
516			18	15	45	100	50
631			22	15	45	100	70
510	14 x 50	WN	16	15	45	100	60
637			20	15	45	100	100
500	16 x 56	764	14	18	54	130	60
643			18	18	54	130	85
714			20	18	54	130	110
612	16 x 64	WN	15	18	54	130	80
694			17	18	54	130	110
816			20	18	54	130	150
523	18 x 63	764	13	20	56	140	60
643			16	20	56	140	90
723			18	20	56	140	110
813	19 x 75	WN	17	20	60	140	210
908			19	20	60	140	290
625	20 x 70	764	14	23	63	150	80
714			16	23	63	150	115
803			18	23	63	150	150
823	22 x 86	WN	15	23	63	150	240
877			16	23	63	150	245
932			17	23	63	150	300
987			18	23	63	150	350
715	23 x 80	764	14	27	73	150	170
816			16	27	73	150	190
918			18	27	73	150	210
697	26 x 91	764	12	30	80	180	150
813			14	30	80	180	180
928			16	30	80	180	235
1020	26 x 100	WN	16	30	80	180	380
1084			17	30	80	180	410
1211			19	30	80	180	440

P:C:D:/TKø = pitch circle diameter, d = diameter, t = pitch, WN = works standard, other dimensions and executions on request. Also available for chains as per other standards. The chain pitch must be equal to the shackle pitch.

HEKO drive chain wheels type GIA, with projecting teeth, are self-cleaning and are ideal for use with sticky and compacting materials, as the teeth push out any product lodged within the chain links. Type GIA has been designed for light and medium duty.

The replaceable toothed rims are manufactured from alloy steel with teeth hardened (contact areas) to reduce wear.

These wheels can be used with horizontal shackles and most other types of attachments. Wheels are supplied with keyway or taper lock bushes, the latter on request. In addition the hubs have holes for spacer bars to adjust for the correct chain centre distance.

Toothed wheels are fitted to eliminate chain slip, usually caused when toothless wheels provide insufficient friction grip, i.e. short shaft centres.

**Fitting instructions see page 34**

## 6.12 Chain wheels with projecting teeth, in steel, with replaceable rim segments, type GIA-3

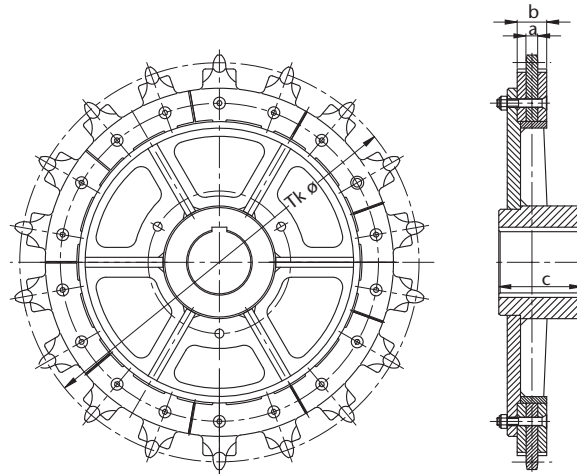


- Suitable as drive wheels for heavy duty applications
- Excellent service life due to hardened contact surfaces
- Suitable for horizontal bucket attachments
- Sprockets consisting of 3 parts

HEKO drive chain wheels, type GIA-3, with projecting teeth, are self-cleaning and are ideal for use with sticky and compacting materials as the teeth push out any product lodged within the chain links. Type GIA-3 has been designed for heavy duty and demanding applications. The replaceable toothed rims and also the outer rim segments are manufactured from alloy steel, teeth with hardened contact areas to reduce wear.

These wheels can be used with horizontal shackle and most other types of attachments. Wheels are supplied with keyway or taper lock bushes, the latter on request. In addition the hubs have holes for spacer bars to adjust for the correct chain centre distance.

Toothed wheels are fitted to eliminate chain slip, usually caused when toothless wheels provide insufficient friction grip, i.e. short shaft centres.



**Figure 58:**  
HEKO chain wheels with projecting teeth (inside toothed), in steel, with replaceable rim segments, type GIA-3

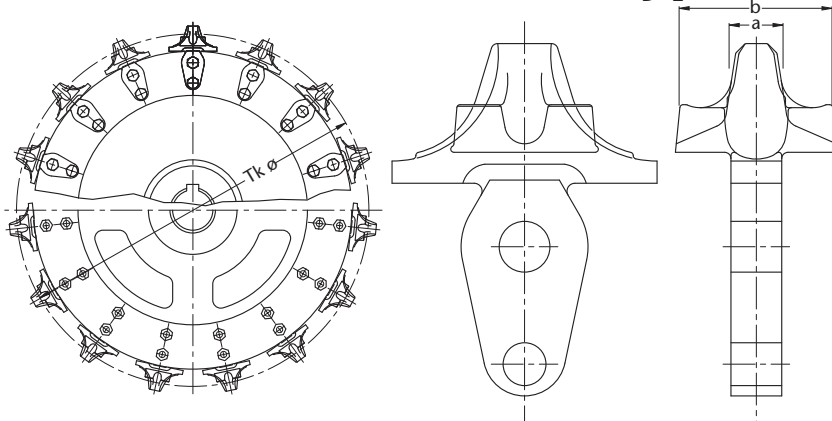
**Table 23: Dimensions for chain wheels type GIA-3**

P.C.D. chain wheel mm, Tkø	to suit chain nominal diameter x pitch, d x t/mm	DIN	number of teeth	dimensions in mm			weight kg/each approx.
				a	b	c	
523	18 x 63	764	13	20	54	140	85
643			16	20	54	140	125
723			18	20	54	140	150
670	19 x 75	WN	14	20	60	140	140
765			16	20	60	140	205
861			18	20	60	140	245
625	20 x 70	764	14	23	63	150	130
714			16	23	63	150	195
803			18	23	63	150	230
768	22 x 86	WN	14	25	71	150	240
877			16	25	71	150	300
987			18	25	71	150	340
715	23 x 80	764	14	27	72	150	225
816			16	27	72	150	285
918			18	27	72	150	320
697	26 x 91	764	12	30	80	180	195
813			14	30	80	180	260
928			16	30	80	180	350
766	26 x 100	WN	12	30	80	180	210
893			14	30	80	180	285
1020			16	30	80	180	385
804	30 x 105	764	12	35	95	200	390
938			14	35	95	200	450
1071			16	35	95	200	510
919	30 x 120	WN	12	35	95	200	445
1072			14	35	95	200	510
1224			16	35	95	200	580
1042	34 x 136	WN	12	35	105	220	520
1215			14	35	105	220	630
1388			16	35	105	220	840
965	36 x 126	764	12	40	110	220	480
1125			14	40	110	220	580
1285			16	40	110	220	780
1042	39 x 136	764	12	45	115	240	640
1215			14	45	115	240	730
1388			16	45	115	240	850
1126	42 x 147	764	12	50	120	250	730
1313			14	50	120	250	890
1406			15	50	120	250	940

P.C.D./Tkø = pitch circle diameter, d = diameter, t = pitch, WN = works standard, other dimensions and executions on request. **Also available for chains as per other standards.** The chain pitch must be equal to the shackle pitch.

Fitting instructions see page 34

## 6.13 Chain wheels with projecting teeth, in steel, with individually replaceable teeth type RIS and return wheels type BS



**Figure 59:**  
HEKO chain wheel type RIS, with replaceable projecting teeth

- Suitable as drive wheels
- Replaceable fabricated individual teeth, forged or cast

- Suitable for endless chain strands with plug-in bucket attachments

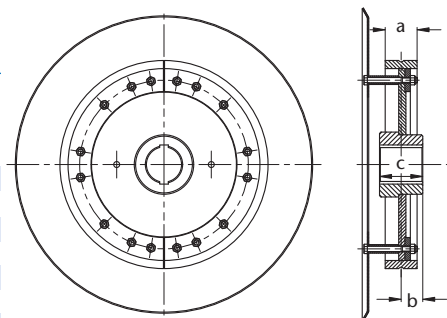
**Table 24: Dimensions for chain wheels type RIS with replaceable projecting teeth and chains to works standard**

P.C.D. of chain wheel mm, Tkø	to suit chain nominal diameter x pitch, d x t/mm	number of teeth	dimensions in mm			weight kg/each approx.
			a	b	c	
510	14 x 50	16	15	45	100	70
637		20	15	45	100	115
612	16 x 64	15	18	54	130	125
694		17	18	54	130	150
816		20	18	54	130	150
813	19 x 75	17	20	60	140	210
908		19	20	60	140	290
823	22 x 86	15	23	63	140	240
877		16	23	63	140	245
932		17	23	63	140	300
987		18	23	63	140	350
1020	26 x 100	16	30	80	180	400
1084		17	30	80	180	410
1211		19	30	80	180	440
1072	30 x 120	14	35	95	200	410
1224		16	35	95	200	450
1377		18	35	95	200	630
1215	34 x 136	14	35	105	200	490
1301		15	35	105	200	580
1388		16	35	105	200	680
1286	38 x 144	14	40	110	220	640
1378		15	40	110	220	640
1469		16	40	110	220	895

P.C.D./Tkø = pitch circle diameter, d = diameter, t = pitch, WN = works standard, other dimensions and executions on request.

**Table 25: HEKO return wheel type BS, with replaceable guide discs**

thread diameter mm	dimensions in mm			weight kg/each approx.
	a	b	c	
540	110	70	140	100
575	100	70	140	125
630	100	70	140	135
730	120	70	140	170
800	120	80	160	210
870	140	80	160	250
980	190	80	160	320
1095	190	80	160	450
1160	195	100	200	500
1280	195	100	200	560
1550	195	110	220	650



**Figure 60:** HEKO return wheel type BS, with replaceable bucket guide discs from alloy steel

Chain wheels with replaceable teeth are recommended for bucket elevators fitted with plug-in attachments type ST. Individual teeth can also be supplied as replacement for fitting to existing hubs, or for chains with larger or different pitches to those listed.

Compatible return wheels with bucket guide discs are manufactured from alloy steel. Diameter of guide discs approx. 400 mm bigger than outside diameter of roller (up to 1010 mm roller diameter) 500 mm for roller over 1110 mm diameter.

**Fitting instructions see page 34**

## 6.14 Chain wheel overview

Replaceable toothless and toothed segments ensure fast and cost effective replacement of worn parts. Shaft and drive removal is unnecessary. Shut-down time is therefore minimised. Wheel segments, teeth and hubs can be produced from special materials, such as stainless steel, HARDOX, etc., on request. Matching of chain and wheel in our workshop

will ensure smooth plant operation. When replacing worn chains, excess wear of retained components should be avoided and we recommend that both chains and wheels, especially toothed wheels, are changed at the same time. Detailed manufacture of chain wheels may vary from those illustrated in the catalogue, drawing of the actual wheel can be provided.

Wheel tolerances are to DIN 7168. Chain wheels can be supplied pilot bored, finish bored and with standard or bespoke hub diameter and length. Toothless drive wheels transport the chain by friction grip, whilst toothed wheels transport the chain by engagement with the tooth. Chain wear is in direct relation to the movement of the link contact areas. The larger the

**Tabelle 26: Übersicht der HEKO Kettenräder**

wheel type	RUH	RUHS	RUA	RUU	SUR
description see page	17	17	18	19	20
machined segments			●	●	●
fabricated toothed rim					
iprojecting teeth (inside toothed)					
pocket teeth					
toothless	●	●	●	●	●
replaceable toothed rim					
replaceable segments	●	●	●	●	●
steel toothed rims and segments			●	●	
chilled cast iron segments				●	
core made of grey cast iron/steel	●	●			
chamfered drop-out openings for sticky products (self-cleaning)					
tapered chain slots (self-cleaning effect)			○	○	
drop-out slots for material	●	●	●		●
large material drop-out openings				●	
suitable for horizontal shackle to type DIN/TS/S	●	●	●	●	●
suitable for vertical shackle to type DIN/TS/S	●	●	●	●	●
suitable for horizontal chain locks type B/D/E	●	●	●	●	●
suitable for vertical chain locks type B/D/E	●	●	●	●	●
suitable for plug-in bucket connector type ST			○	○	
suitable for chain wire diameters from – to (mm)	13-39 mm	13-39 mm	10-42mm	10-42mm	13-42mm
suitable for chain to DIN 764	●	●	●	●	●
suitable for chain to DIN 766	●	●	●	●	●
suitable for chains to works standard	●	●	●	●	●
suitable for chains in special executions	●	●	●	●	●
stainless steel or other materials to suit client			○	○	
steel hub	●	●	●	●	●
cast iron hub	●	●			●
wheels completely made from special alloy steel			○	○	
cast iron wheels					
recommended as drive wheels	●	●	●	●	
recommended as return wheel	●	●	●	●	●
recommended as snub wheel	●	●		●	●
keyway to DIN	●	●	●	●	●
keyways in special executions or taper lock bush	●	●	●	●	●
suitable as loose wheel	●	●	●	●	●
inclusive of grub screw central to keyway	○	○	○	○	○
segments encased in plastic	●	●			
corrosion protection paint	●	●	●		●

● standard, ○ special



P.C.D., the smaller the movement and therefore the smaller the wear. Also smaller shaft centres increase the movement and thus chain wear. Toothless chain wheels increase the service time of chains.

KS	KSE	GGB	RUR	RUP	RUG	GTA	GIA	GIA-3	RIS
20	20	21	21	22	23	24	25	26	27
●	●		●	●	●	●	●	●	
						●	●	●	
		●							
●	●	●	●	●	●				
		●				●	●	●	
●	●		●	●	●				
		●	●	●		●	●	●	●
●	●								
			○	○		○	○		○
●	●	●			●				●
			●						●
	●		●	●	●		●	●	
●	●	●	●	●	●	●			
	●		●	○	●		●	●	●
●	●	●	●	●	●				
			○			●	●	●	
13-36mm	13-36mm	13-36mm	10-42mm	16-36mm	16-42mm	10-42mm	10-26mm	10-42mm	14-38mm
●	●	●	●	●	●	●	●	●	●
●	●	●	●	●	●	●	●	●	●
●	●	●	●	●	●	●	●	●	●
●	●	●	●	●	●	●	●	●	●
		○	○	○		○	○	○	○
●	●		●	●	●	●	●	●	●
●	●								
		○	○	○		○	○	○	○
	●								
		●	●	●		●	●	●	●
●	●	●	●		●				
●	●	●	●						
●	●	●	●	●	●	●	●	●	●
●	●	●	●	●	●	●	●	●	●
●	●	●	●	●	●	●	●	●	●
○	○	○	○	○	○	○	○	○	○
●	●	●		●	●	●	●	●	●

## 7.0 HEKO elements for bucket elevators

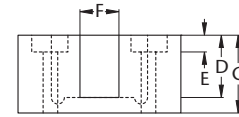
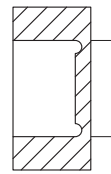
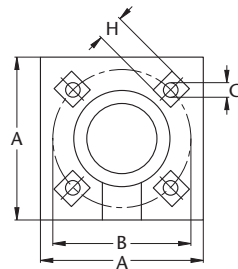
### 7.1 Maintenance-free bearings for bucket elevators and other conveyors



**Figure 61:**  
HEKO bearing housing with bush

HEKO bearings have the advantage of being able to be fitted inside the elevator boot. These bearings operate successfully with many dry or moist products, including abrasive products, but may also be used submerged in water.

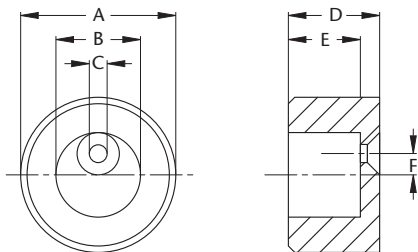
The CrNi steel bearing bush, which forms the shaft liner, is secured to the shaft by a screw. The bush runs inside the bearing housing without lubrication. The bearing housing, manufactured from special cast alloy steel, is fixed to the tensioning device by four bolts. Dust seals etc. are not required.



**Figure 62:** HEKO bearing housing

**Table 27: Dimensions of HEKO bearing blocks for bucket elevators**

type	A	B	C	D	E	F	G	H	I
LGH 18-4	178	165	82	65	18	52	17	30	112
LGH 18-11	230	203	108	90	20	55	21	34	138



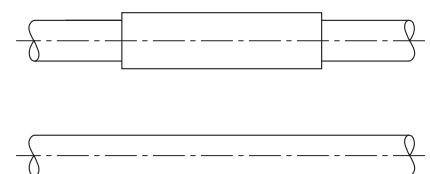
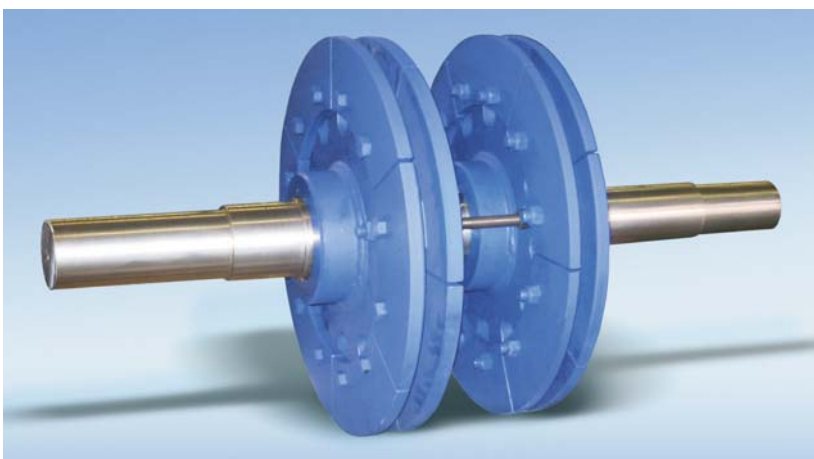
**Figure 63:** HEKO bearing bush

**Table 28: Dimensions for HEKO bearing bushes**

type	A	B*	C	D	E	F	max load**	U/min max**
LGH 18-4	110,2	60	17	64	54	15	700 kg	50-60
LGH 18-4	110,2	74,5	21	64	54	15	700 kg	50-60
LGH 18-11	135,4	87,3	21	88,9	80	27	1200 kg	50-60
LGH 18-11	135,4	100	21	88,9	80	27	1200 kg	50-60

\*Other dimensions on request \*\*Depending on conveying material and equipment.

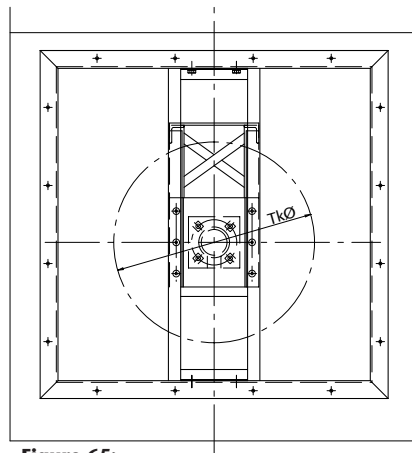
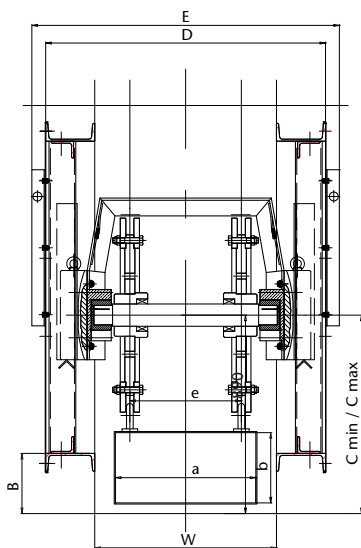
### 7.2 Drive and return wheel shafts



**Figure 64:** Assembled HEKO wheel shaft

Precision machined shafts can be supplied manufactured from carbon steel, CrMo-steel or CrNiMo-steel, including tempered for higher loads. Shaft can, on request undergo ultrasonic testing before dispatch. Shaft dimensions to suit client.

## 7.3 Return and tensioning unit for bucket elevators



**Figure 65:**  
Drawing of a return and tensioning unit.  
Picture right corner: Assembly of a HEKO return unit.



- For new and existing elevators – 160 to 1600mm bucket width
- Minimal maintenance due to automatic self-tensioning and maintenance free bearings
- No dust emission due to internal bearings

The return and tensioning unit is completely encased inside the elevator boot, thus preventing dust emission. The shaft is supported by maintenance free, dry, bearings, the latter manufactured from alloy steel. HEKO's return and tensioning unit is designed for easy access to replace worn parts, thus minimising downtime. All standard units, type I, II & III, for new elevators, as well as units in

special executions for existing elevators. HEKO also provide conversions for problem belt and bucket elevators, as frequently experienced in cement grinding plants. Conversion time can be minimised as the return and idling unit can be supplied pre-assembled. The return and idling unit includes the wheels with replaceable steel segments, shaft, bearings, slide rails

and carriage, weight box, mounting frames for welding to the boot walls and large bolted access door each side. The self-weight of the wheels, shaft and bearings is normally sufficient to provide adequate chain tension. However, elevators with short shaft centres may require additional weights to be placed into the weight box of the return and tensioning unit.

**Table 29: Dimensions for HEKO return and tensioning unit type I**

Width	Type	A	B	Cmin/Cmax	D	E	P.C.D.	W	a	b	e
315	DIN	420	435	630/1030	605	705	630	485	315	200	200
315	HL	445	460	655/1055	605	705	630	485	315	224	200
250	DIN	415	430	625/1025	550	650	630	430	250	200	160
250	HL	415	430	625/1025	550	650	630	430	250	200	160
200	DIN	305	320	515/915	485	585	500	365	200	160	125
200	HL	325	340	535/935	485	585	500	365	200	180	125
160	DIN	305	320	515/915	450	550	500	330	160	160	100

**Dimensions for HEKO return and tensioning unit type II**

Width	Type	A	B	Cmin/Cmax	D	E	P.C.D.	W	a	b	e
630	DIN	620	635	865/1365	1010	1130	900	810	630	280	400
630	HL	655	670	900/1400	1010	1130	900	810	630	315	400
500	DIN	535	550	780/1280	880	1000	800	680	500	250	315
500	HL	565	580	810/1310	880	1000	800	680	500	280	315
400	DIN	460	475	705/1205	770	890	710	570	400	224	250
400	HL	485	500	730/1230	770	890	710	570	400	250	250

**Dimensions for HEKO return and tensioning unit type III**

Width	Type	A	B	Cmin/Cmax	D	E	P.C.D.	W	a	b	e
1600	DIN	1035	1080	1375/1975	2010	2130	1500	1810	1600	450	1000
1600	HL	1115	1130	1425/2025	2010	2130	1500	1810	1600	500	1100
1400	DIN	990	1005	1300/1900	1810	1930	1400	1610	1400	425	900
1250	DIN	890	905	1200/1800	1660	1780	1250	1460	1250	400	800
1250	HL	940	955	1250/1850	1660	1780	1250	1460	1250	450	800
1000	DIN	840	855	1150/1750	1410	1530	1250	1210	1000	355	630
1000	HL	885	900	1195/1795	1410	1530	1250	1210	1000	400	630
800	DIN	665	680	975/1575	1210	1330	1000	1010	800	315	500
800	HL	705	720	1015/1615	1210	1330	1000	1010	800	355	500

# 8.0 Example of bucket elevator sizing

**Table 30: Bucket elevator calculation**

Customer: \_\_\_\_\_ Customer's ref.: \_\_\_\_\_

Bucket elevator data:

Automatic calculation:			
C required handling rate	Q	[t/h]	350
A	V	[m³/h]	259
C required shaft centres	A	[m]	35
C product			cement
C bulk density	lv	[kg/m³]	1350
C moisture		[%]	10%
C temperature	T	[°C]	100°
S bucket material			St. 37
A max. handling rate	QT	[t/h]	585
bulk density			
A	VT	[m³/h]	433
A est. power absorbed at req. handling rate		[kw]	54,56
A est. power absorbed at max.handling rate			91,13
S req. motor power	Pa	[kw]	
A drive wheel speed		[rpm]	19,87
S chain speed	v	[m/s]	1,3
A bucket filling degree at req.handling rate	ρ	[%]	59,86
A bucket distance	aB	[mm]	630
Chain wheels			
S drive wheel P.C.D.:	Tkø	[mm]	1250
S return wheel P.C.D.:	Tkø	[mm]	1250
weight return wheel	RG	[kg/pc.]	630
S chain wheel type drive			HEKO type RUA
S chain wheel type return			HEKO type RUUI
Buckets			
A calculated no. of buckets	nB		117,3
S actual no. of buckets	nBe		118
S bucket size	B	[mm]	1000 x 355 x 6
S DIN/type/drawing			DIN 15234
S bucket content	Bi	[litre]	58,3
S bucket weight	Bg	[kg]	53
Chain size and attachments			
S chain wire size		[mm]	30
S chain pitch	t	[mm]	105
S no. of links	n		5
S chain type/DIN			DIN 764
S chain Quality			HEKO 400 E
S min. breaking load	MBL	[kN]	565
S attachment size/pitch	Bt	[mm]	105
S weight total chain strand	KG	[kg/m]	22,5
A effective strand length	Le	[m]	74,340
A calculated strand length	L		73,925
A calculated shaft centres	AT	[m]	35,21
A max. chain load at req. handling rate	P	[kN]	49,54
A max. chain load at 100% full buckets		[kN]	58,68
A <b>safety factor</b> at req. handling rate			11,18
A safety factor at 100% full buckets			9,63
total dead weight on return wheels		[kg]	2520

C = customers information, S = recommendation HEKO, A = automatic calculation

Customer's ref.: \_\_\_\_\_

**used formulas for calculation**

$$V = \frac{Q}{lv} = \frac{350}{1,35} = 259 \text{ m}^3/\text{h}$$

$$Q_T = \frac{3600 \cdot lv \cdot Bi \cdot v}{aB} = \frac{3600 \cdot 1,35 \cdot 58,3 \cdot 1,3}{630} = 585 \text{ t/h}$$

$$V_T = \frac{Q_T}{lv} = \frac{585}{1,35} = 433 \text{ m}^3/\text{Std.}$$

$$\rho = \frac{Q \cdot aB \cdot 100}{3600 \cdot Bi \cdot lv \cdot v} = \frac{350 \cdot 630 \cdot 100}{3600 \cdot 58,3 \cdot 1,35 \cdot 1,3} = 59,86 \%$$

$$aB = n \cdot t + Bt = 5 \cdot 105 + 105 = 630 \text{ mm}$$

$$nB = L/aB = 73,925/0,63 = 117,3$$

$$L_e = nB_e \cdot aB = 118 \cdot 0,63 = 74,34 \text{ m}$$

$$L = 2 \cdot A + (Tkø \cdot \Pi) = 2 \cdot 35 + (1,25 \cdot 3,1415) = 73,925 \text{ m}$$

$$AT = \frac{L_e - (Tkø \cdot \Pi)}{2} = \frac{74,34 - (1,25 \cdot 3,1415)}{2} = 35,21 \text{ m}$$

effective lengths of chain strand · weight of chain strand + effective no. of buckets · (bucket weight + bucket contents · bulk density · bucket filling) degree/2 + 4 · weight return wheel = total load 2 strands (kg)

load 1 strand (F) = total load 2 strands / 2 (kg)

$$S = \frac{MBK \cdot 100}{F} = \frac{565 \cdot 100}{5049,65} = 11,18$$

The safety factor must be min. 8 for bucket elevators. At a safety factor of more than 15 it may be more economic to use a different chain quality or size.

<b>Bulk Densities:</b>	<b>kg/m<sup>3</sup></b>
Ash, dry	550-650
Asphalt	700
Bauxite	1200-1400
Chrome ore	2000
Dolomite, crushed	1250-1600
Iron ore	2000-3000
Flyash, dry	500-720
Gypsum	900-1000
Gypsum, dry	850-1000
Glass	1300-1600

Granite	1250-1600
Limestone, hydrated	1200
Limestone, calcined	900
Limestone, crushed	1300-3000
Gravel and sand, wet	1600-1800
Coal	800
Phosphate	2000
Quartz	1600-1750
Sand, dry	1500-1600
Slag sand	900
Stones under 100 mm	1450-1600
Cement, clinker	1200-1300

Cement, raw meal	800-1000
Cement, dry	1350-1600
Sugar-Beet	600
<b>Technical Details</b>	
V = speed = P.C.D. · $\frac{\pi}{60}$ [m/s]	
Hub max. = P.C.D. - (b + 2 · dia.) [mm]	
Length of hub NL = Bore · 1,20 [mm]	
Dia. of hub ca. = Bore · 1,65 [mm]	
P.C.D. = $\frac{t}{s}$ {s = sin (90/no. of teeth)} [mm]	

## 9.0 General technical information

### Chain Assembly:

HEKO supply chain ends with 5,7,9 or more links, long chain strands and endless chain strands pre-assembled with TS-shackles.

#### Chain ends:

Chains ends are always supplied as matched pairs. Bundles are tied together with coloured wire, colour depending on chain quality as follows:

HEKO 280E – white  
 HEKO 21 – yellow  
 HEKO 210E – black  
 HEKO 400E – green  
 HEKO 5 – red  
 HEKO 350E – blue

Wire should not be removed until directly before commencing assembly and chain ends of each pair must be assembled next to each other to avoid chain misalignment. Chains should be assembled with the welds pointing towards the shaft centre.

Long chain strands and endless chain strands pre-assembled with

#### TS-shackle:

Long chains strands, max. length up to 400kg per length.

Long chain strands and endless chain strands will be supplied in matched pairs to avoid misalignment. One end of each strand is colour coded.

Coloured links of each strand must be assembled next to each other, colours will be advised in the delivery note.

#### General

Chain ends fitted with DIN or similar D-shackles require the buckets to be fitted before lifting into the housing to minimise the risk of hairline cracks forming in the shackle. Chain assemblies with the TS-shackle system, or long chain strands may be lifted into housing and fitted without

buckets without incurring the risk of cracks, the latter may be fitted after the chains have been made endless. Pre-assembly of internal components substantially reduces downtime for re-chaining.

Accurate alignment of drive and idling wheels, parallel drive and idling shafts and correct chain centres are essential for trouble-free operation. Chain tension should be adequate to ensure free, low noise chain movement.

Noise, which may arise from the rubbing together of two steel surfaces and resonant frequencies are often caused by excess chain tension.

Proper chain tension must be assured at all times by employing an efficient, preferably, self-tensioning device.

### Shortening of chain

Should it be necessary to shorten the chain, only a complete pair of chain ends, with equal number of links, should be removed. Removing links from long chain strands may be carried out by cold cutting, using a cutting disc. As individual chain links may have different tolerances, some misalignment should be expected when removing individual links. Heating the chain or welding should be avoided. HEKO will be pleased to advise.

### Maintenance/Wear

#### Measurement:

All conveyor parts which may be subject to wear (wheels, chains, bucket attachments, chain locks) should be checked regularly for wear or damage. Chain contact surfaces are subject to normal wear, the extent of which depends on chain quality, number of link movements, contact load and material handled. Wear in the contact areas reduces the chain thickness and thus has a direct relationship to service life. Lubrication,

for example with oil, or increased moisture content in the product increases wear, especially with abrasive materials. Wheel scrapers and other devices that clean the wheel grooves reduce wear. Chains, wheels and bucket attachments should be checked thoroughly following an overload condition. Chains and chain wheels, or wheel rims, especially toothed wheels, should always be replaced at the same time.

Generally we recommend replacement of the chain when 75% of the hardening depth is worn and less when toothed wheels are fitted. Damaged or distorted buckets affect the chain centres, causing a contact between the wheel groove, chain and shackle and resulting in premature chain/shackle failure. Such buckets must be replaced or corrected as soon as possible. Nuts, securing the buckets should also be checked regularly and re-tightened as necessary.

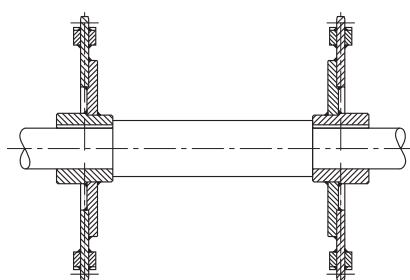
### Operational Information

Central feed is essential for avoiding uneven bucket filling and uneven wear between the two chain strands. If feed conveyors approach the elevator inlet at 90°, corrective measures are recommended by use of deflactors, swept inlet or convex inlet floor. Elevator buckets must be fitted completely horizontally. Bucket attachment nuts should be tightened using a torque spanner, ideally when resting on the drive wheels to ensure that correct chain centres are maintained. After approx. 2 weeks operation, all nuts should be re-tightened. We recommend the use of safety discs or self-locking nuts to secure the bucket. Loose buckets could lead to shearing of attachment bolts, and, when using DIN type shackle, to premature fractures due to fatigue.



**Table 31: Recommended torque setting**

For hexagon nuts to DIN 555 grade 5		For hexagon nuts to DIN 934 grade 8		For self-locking steel nuts to DIN 980V grade 8	
M 10	30 Nm	M 10	51 Nm	M 10	55 Nm
M 12	52 Nm	M 12	89 Nm	M 12	95 Nm
M 14	83 Nm	M 14	140 Nm	M 14	149 Nm
M 16	127 Nm	M 16	213 Nm	M 16	225 Nm
M 20	245 Nm	M 20	420 Nm	M 20	439 Nm
M 24	420 Nm	M 24	725 Nm	M 24	752 Nm
M 30	847 Nm	M 30	1451 Nm	M 30	1487 Nm
M 36	1480 Nm	M 36	2531 Nm	M 36	2575 Nm

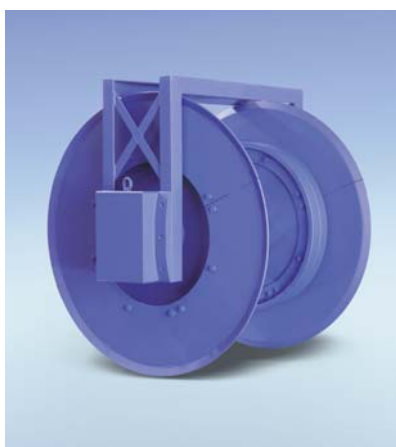


**Figure 66: Assembly instruction**

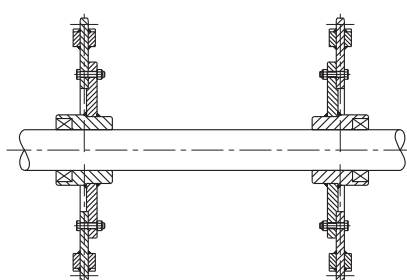
**Assembly of one-piece chain wheels.**

(see Figure 66)

Unless otherwise instructed by clients, keyways will be cut in a pair of wheels central to both teeth. Chain wheels belonging together will be given the same number so that mistakes are avoided even with a large number of wheels. Each pair of wheels will be marked with the same number sequence.



**Figure 68: Pre-assembled HEKO Return and Tensioning unit, complete with segmented rims and spacer bars.**



**Figure 67: Assembly instruction**

**Assembly for chain wheels with replaceable sprockets/rim segments**

(see Figure 67)

Unless otherwise instructed by clients, keyways will be cut in a pair of wheels central to both teeth. Chain wheels belonging together will be given the same number so that mistakes are avoided even with a large number of wheels. Each pair of wheels will be marked with the same number sequence. Each part of the wheel with replaceable segments will be marked with an additional number to ensure that re-fitting is in the correct sequence. Segments can be exchanged with chains still in place.

**General**

Several options for locating the wheels to the shaft are available. Grub screws, or locating rings with groove to DIN6885/1 or similar and keywayed, to DIN6887 or similar, or taper lock bushes are used for stepped shafts.

**Taper lock bushes**

Both toothless and toothed chain wheels are more easily located by use of taper lock bushes. Weakening of the drive shaft by keyways is

avoided enabling higher loads to be accommodated or the shaft size reduced.

**Spacer bars**

Spacer bars, in the form of threaded rods, simplifies axial adjustment of the chain wheels to achieve and maintain the correct chain centres. Once locked, both wheels can be moved together on the shaft for correcting the vertical alignment between drive and idling wheels.

**Individual teeth**

The holding disc must be loosened and moved away from the hub when changing teeth. Teeth are exchanged in the no-load area (i.e. not in contact with the chain). Bolts must initially be tightened by hand only. Once all teeth have been fitted, bolts should be fitted when in the upper position, using a torque wrench set to the torque recommended by HEKO. (table 30)

**Shackles type DIN 745/5699**

DIN 745 has been replaced by DIN 5699, the latter being a stronger shackle. When exchanging DIN 745 with shackles to DIN 5699 or TS-Shackle, it should be noted that while the pitch is the same, the bolt diameter for pitch sizes 45, 56, 136 differ and require larger holes. Also dimension 'a' is different which can usually be accommodated by adjusting the through-of plate at the outlet.

# 10.0 Questionnaire – Technical Data for Bucket Elevators

Company .....  
 address .....  
 contact ..... ref. no. ....  
 tel ..... fax ..... e-mail .....

## 1. Type of conveyor

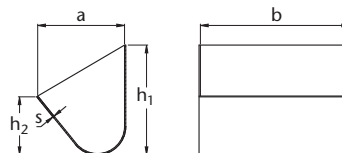
single strand                       double strand

## 2. Material to be conveyed

type of material .....  
 dry                       wet                       adhesive                       corrosive  
 very abrasive                      moisture ..... (%)                      temperature ..... °C  
 bulk density ..... (t/m<sup>3</sup>)                      particle size .. to ..... (mm)

## 3. Bucket

h1 ..... (mm) contents ..... (ltr.)  
 h2 ..... (mm) weight ..... (kg)  
 a ..... (mm) DIN standard .....  
 s ..... (mm) bucket distance ..... (mm)  
 b ..... (mm)



4. Shaft centre distance ..... (mm)

5. Handling Rate ..... (t/h) ..... (m<sup>3</sup>/h)

6. P. C. D. of drive wheels ..... (mm)

toothless                       pocket toothed                       inside toothed                      no. of teeth .....

P. C. D. of return wheels ..... (mm)

Chain speed ..... (m/sek)                      Drive wheel speed ..... (U/min)

Power absorbed – drive shaft ..... (kW)

7. Annual operating hours ..... (h)

## 8. Chains used to date

round steel chain                       central chain                       plate link chain                       belt

### Details of chains

#### a) round steel chains

diameter ..... (mm)                      pitch ..... (mm) ..... (quality)

chain ends                      no. of links ..... (piece)

endless chain strand

#### b) plate link chain

dia. of bush and bolt ..... (mm)                      pitch ..... (mm)

dimensions of plates ..... (mm)

### Details of attachments

#### a) round steel chains

chain shackle ..... (DIN) ..... (pitch) ..... (quality)

plug in attachment                       bucket finger                       chain clamp

others .....

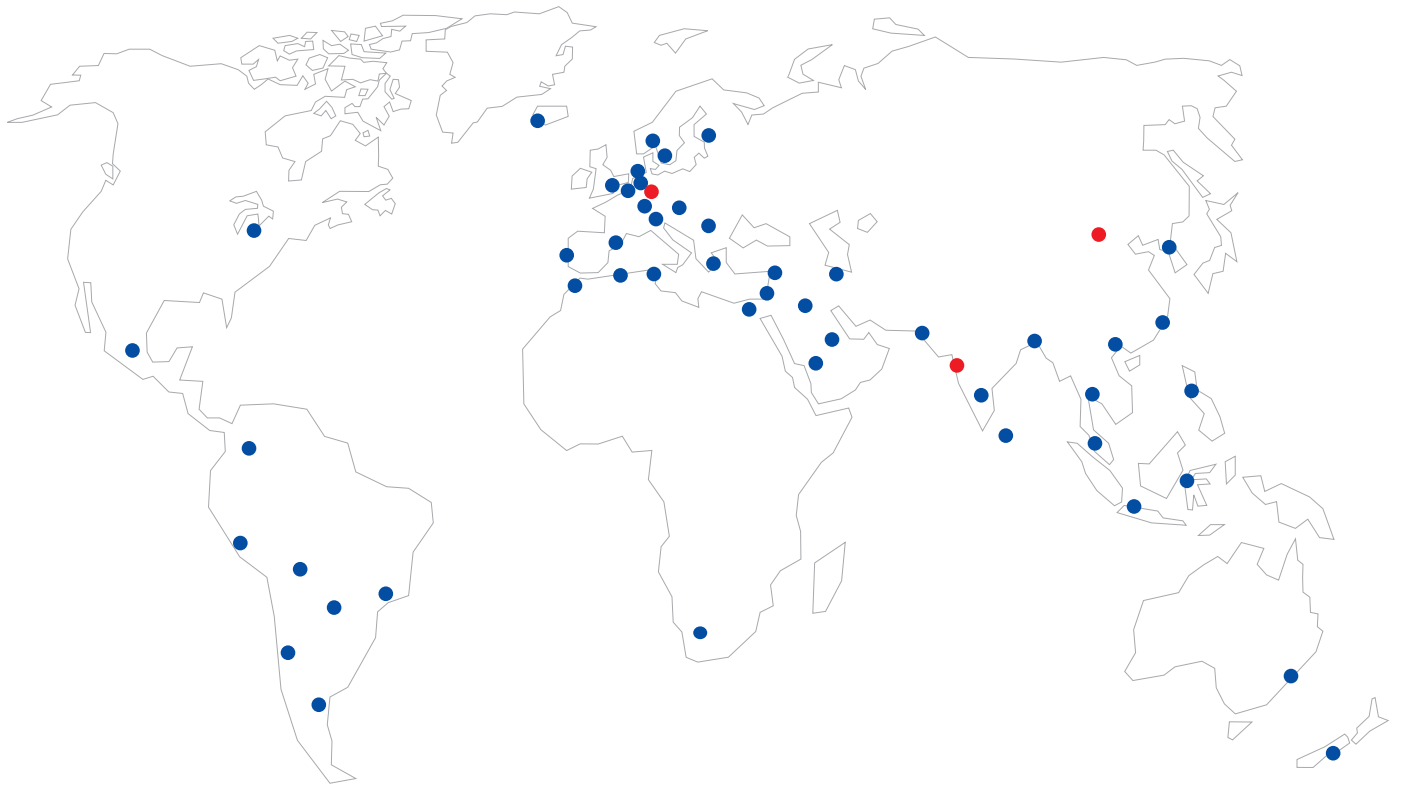
#### b) plate link chain

dimensions of attachment angles ..... (mm)

9.  New plant                       existing plant                       modification                       refurbishment

10. Apparent problems .....

Please attach specification or sketch for special requirements.



HEKO is represented in over 50 countries around the world

Made in Germany



HEKO Ketten GmbH | Postfach 1262 | D-58732 Wickede (Ruhr) | Eisenbahnstraße 2 | D-58739 Wickede (Ruhr), Germany  
Telephone: +49 23 77-91 80-0 | Fax: +49 23 77-10 28 | Internet: [www.HEKO.com](http://www.HEKO.com) | E-Mail: [info@HEKO.com](mailto:info@HEKO.com)

